

LoadLifter 5000™

**Kit 57230**  
***Dodge 1500***  
***4-Wheel Drive***



**INSTALLATION GUIDE**

For maximum effectiveness and safety, please read these instructions completely before proceeding with installation.

*Failure to read these instructions can result in an incorrect installation.*

# **Protect your Air Lift Purchase by Completing your Warranty Registration**



Thank you for purchasing an Air Lift load support product!

Take a photo of your sales receipt and then scan the QR code to complete your online warranty registration.



# TABLE OF CONTENTS

<b>Introduction</b> . . . . .	<b>2</b>
Important Safety Notice . . . . .	2
Notation Explanation . . . . .	2
<b>Installation Diagram</b> . . . . .	<b>3</b>
<b>Hardware and Tools Lists</b> . . . . .	<b>4</b>
<b>Installing the LoadLifter 5000 System</b> . . . . .	<b>5</b>
Getting Started . . . . .	5
Tech Tip Option . . . . .	6
Assembling the Air Spring Assemblies . . . . .	7
Attaching the Upper Brackets . . . . .	8
Attaching the Lower Brackets . . . . .	9
Heat Shield Installation . . . . .	10
Views of the Installed Assembly . . . . .	11
Installing the Air Lines . . . . .	11
<b>Before Operating</b> . . . . .	<b>12</b>
Installation Checklist . . . . .	12
Maintenance and Use Guidelines . . . . .	13
<b>Limited Warranty and Return Policy</b> . . . . .	<b>13</b>



# Introduction

The purpose of this publication is to assist with the installation, maintenance and troubleshooting of the LoadLifter 5000 air spring kit. LoadLifter 5000 utilizes sturdy, reinforced, commercial grade single or double, depending on the kit, convolute bellows. The bellows are manufactured like a tire with layers of rubber and cords that control growth. LoadLifter 5000 kits are recommended for most 3/4 and 1-ton pickups and SUVs with leaf springs and provide up to 5,000 lbs. of load-leveling support with air adjustability from 5-100 PSI. The kits are used in motor home rear applications and various front applications where leaf springs are used.

It is important to read and understand the entire installation guide before beginning installation or performing any maintenance, service or repair. The information here includes a hardware list, tool list, step-by-step installation information, maintenance guidelines and operating tips.

Air Lift Company reserves the right to make changes and improvements to its products and publications at any time. For the latest version of this manual, contact Air Lift Company at (800) 248-0892 or visit our website at [www.airliftcompany.com](http://www.airliftcompany.com).

## IMPORTANT SAFETY NOTICE

The installation of this kit does not alter the Gross Vehicle Weight Rating (GVWR) or payload of the vehicle. Check your vehicle's owner's manual and do not exceed the maximum load listed for your vehicle.

**Gross Vehicle Weight Rating:** The maximum allowable weight of the fully-loaded vehicle (including passengers and cargo). This number — along with other weight limits, as well as tire, rim size and inflation pressure data — is shown on the vehicle's Safety Compliance Certification Label.

**Payload:** The combined maximum allowable weight of cargo and passengers that the truck is designed to carry. Payload is GVWR minus the Base Curb Weight.

## NOTATION EXPLANATION

Hazard notations appear in various locations in this publication. Information which is highlighted by one of these notations must be observed to help minimize risk of personal injury or possible improper installation which may render the vehicle unsafe. Notes are used to help emphasize areas of procedural importance and provide helpful suggestions. The following definitions explain the use of these notations as they appear throughout this guide.



**DANGER**

INDICATES IMMEDIATE HAZARDS WHICH WILL RESULT IN SEVERE PERSONAL INJURY OR DEATH.



**WARNING**

INDICATES HAZARDS OR UNSAFE PRACTICES WHICH COULD RESULT IN SEVERE PERSONAL INJURY OR DEATH.



**CAUTION**

INDICATES HAZARDS OR UNSAFE PRACTICES WHICH COULD RESULT IN DAMAGE TO THE MACHINE OR MINOR PERSONAL INJURY.

## NOTE

*Indicates a procedure, practice or hint which is important to highlight.*

# Installation Diagram

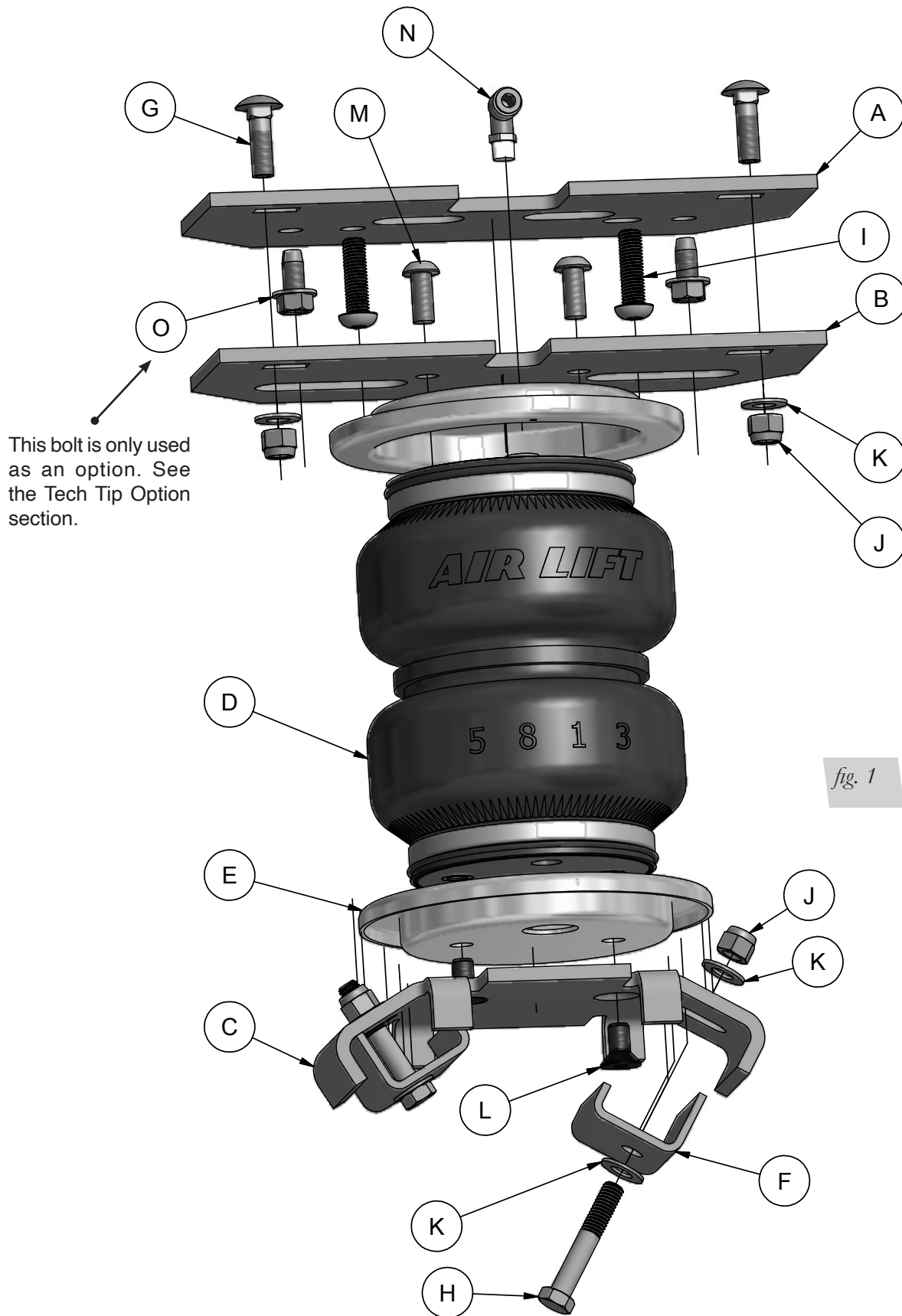

fig. 1

# Hardware and Tools Lists

## HARDWARE LIST

Item	Part #	Description.....	QTY
A	07057	Upper Frame Bracket .....	2
B	07058	Upper Bellows Bracket .....	2
C	03062	Lower Bracket.....	2
D	58437	Bellows .....	2
E	11951	Roll Plate .....	4
F	01663	Lower Bracket Retainer (J Clamp) .....	4
G	17361	3/8"-16 X 1 1/4" Carriage Bolt.....	4
H	17420	3/8"-16 X 2 1/4" Hex Head Bolt.....	4
I	17366	M10-1.5 X 35 Button Head Screw .....	4
J	18435	3/8" Nylon lock Nut.....	8
K	18444	3/8" Flat Washer.....	12
L	17215	3/8"-24 X 7/8" Flat Head Screw .....	4
M	17527	3/8"-24 X 3/4" Button Head Screw.....	4
N	21837	90-degree Swivel Fitting .....	2
O	17151	3/8" X .75" Self Tapping Bolt.....	4
AA	20086	Air Line Assembly.....	1
BB	10466	Zip ties.....	6
CC	21230	Valve Cap .....	2
DD	18501	5/16" Flat Washer.....	2
EE	21234	Rubber Washer .....	2
FF	18411	Star Washer.....	2
GG	21233	5/16" Hex Nut .....	4

## TOOLS LIST

Description.....	QTY
Hoist or Floor Jacks.....	1
Safety Stands .....	2
Safety Glasses .....	1
Torque Wrench .....	1
Standard Open-end Combo Wrenches .....	1
Ratchet.....	1
Metric and Standard Sockets .....	1
#6 Metric Allen Wrench (socket if available).....	1
7/32 Allen Wrench (socket if available).....	1
5/16" Drill Bit (very sharp) .....	1
Heavy Duty Drill.....	1
Hose Cutter, Razor Blade or Sharp Knife.....	1
Air Compressor or Compressed Air Source .....	1
Spray Bottle with Dish Soap/Water Solution .....	1



Missing or damaged parts? Call Air Lift customer service at (800) 248-0892 for a replacement part.

# Installing the LoadLifter 5000 System

## GETTING STARTED

1. Raise the vehicle and support the axle with safety stands, setting the safety stands as wide as possible on the axle (Fig. 2)

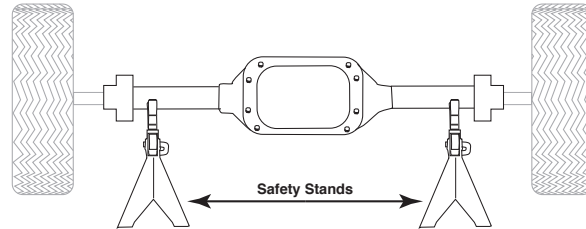

fig. 2

2. Drop the axle or raise the frame up to make room for the assemblies to be put into position between the frame and axle.
3. Remove the jounce bumper from under the frame rail (Fig. 3).

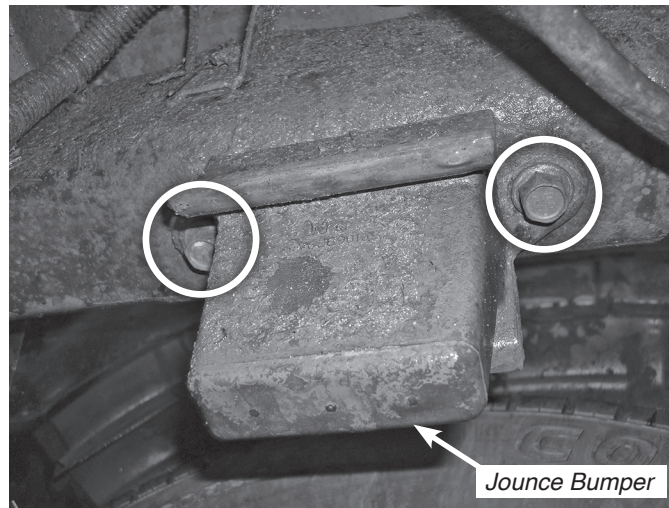

fig. 3

4. Attach the upper frame bracket (A) to the frame using the two M10-1.5 X 35 button head screws (I). Torque to 30 lb.-ft.

### NOTE

*The slot in the frame goes inboard towards the inside of the vehicle (Fig. 4). Repeat this on the opposite side.*

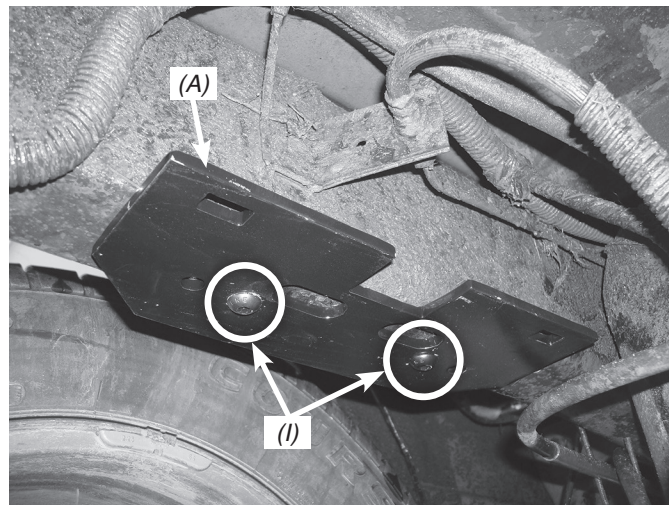

fig. 4

## TECH TIP OPTION

If by chance one of the jounce bumper bolts breaks upon removal, bolt the bracket to the frame as noted above using the jounce bumper mounting hole from which the other bolt was removed, to align the bracket.

1. Line up the hole in the upper bracket over the broken bolt (as if being bolted as stated above).
2. Center punch and drill a 5/16" hole in the center of the outside hole next to the broken bolt hole (Fig. 5).

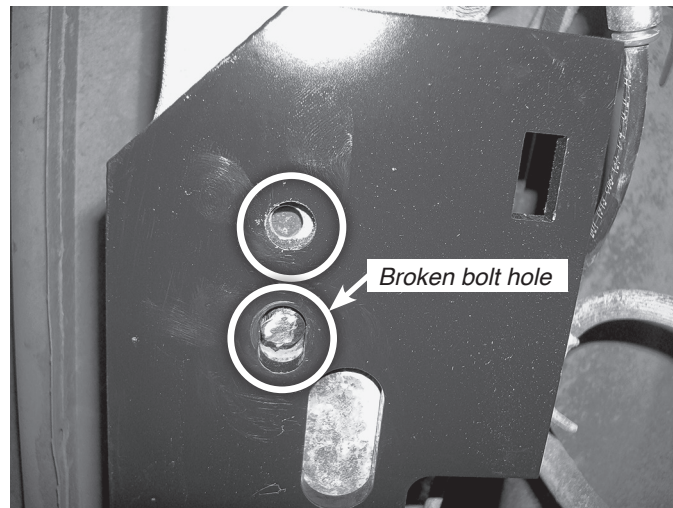

fig. 5

3. Insert and tighten a self-tapping bolt (O) into the hole drilled. Torque the bolt to 15 lb.-ft. (Fig. 6).

## NOTE

Figure 6 shows the upper bracket installed to the frame using the supplied M10 bolt (I) that was removed and a self-tapping bolt. **Use these only if the existing jounce bumper bolts break!**

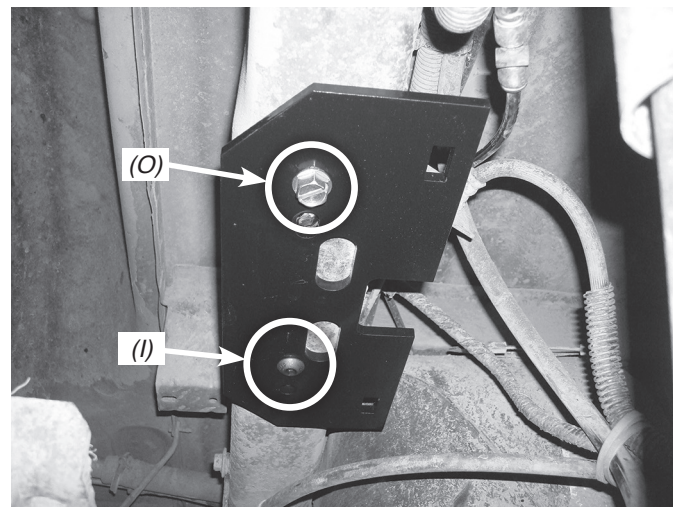

fig. 6



## ASSEMBLING THE AIR SPRING ASSEMBLIES

1. Set a roll plate (E) over the top of each air spring (D).

### NOTE

*The radiused (rounded) edge of the roll plate (E) will be towards the bellows so that the bellows is seated inside both roll plates.*

2. Install the swivel fitting (N) into the top of the air spring finger tight plus one and a half turns (Fig. 7).

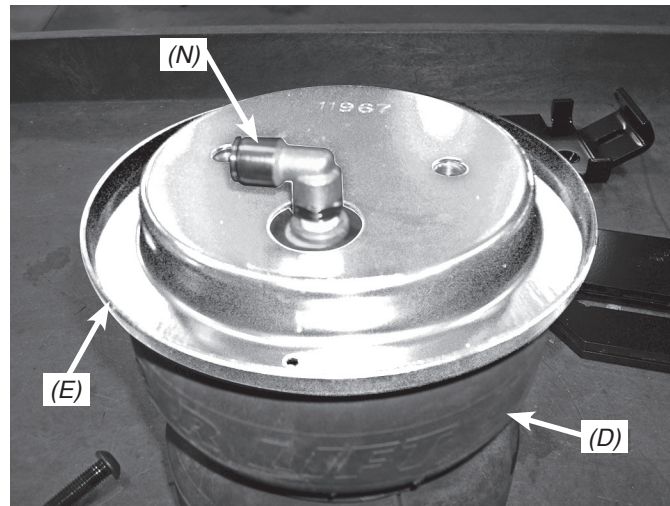

fig. 7

3. Install the air spring bracket (B) onto the air spring and attach using the 3/8"-24 X 3/4" button head screws (M) (Fig. 8). Torque to no more than 20 lb.-ft.

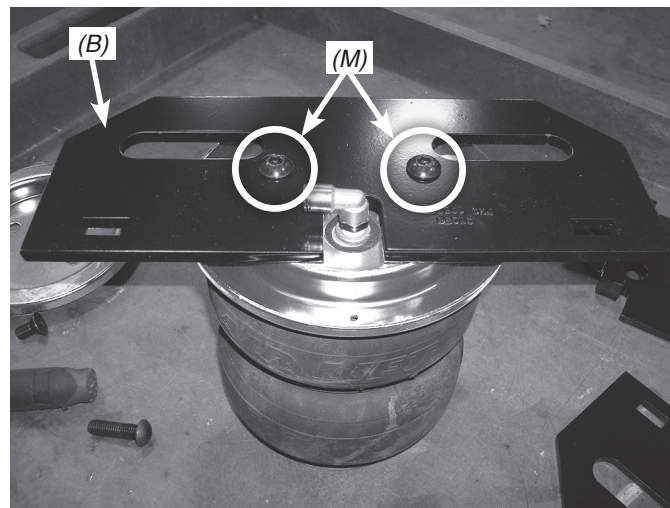
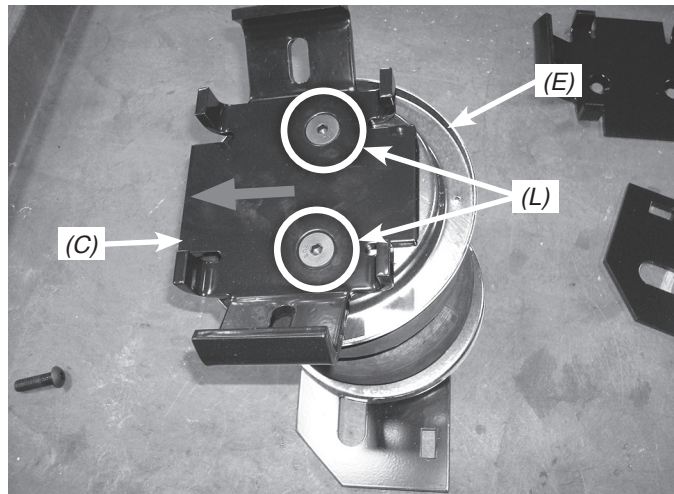

fig. 8

4. Repeat for the other assembly.
5. Flip the assemblies over; set a roll plate (E) onto the bottom of the air spring assembly (fig. 9).
6. Set the lower bracket (C) onto the assembly with the arrow pointing in the opposite direction of the 90-degree swivel fitting, which is on the top of the assembly (fig. 9). Attach the lower bracket with 3/8"-24 X 3/4" flat head screws (L). Torque to no more than 20 lb.-ft.

### NOTE

*The arrow (shown as gray color in Fig. 9) on the lower bracket points opposite of the fitting (points towards the tire once installed).*

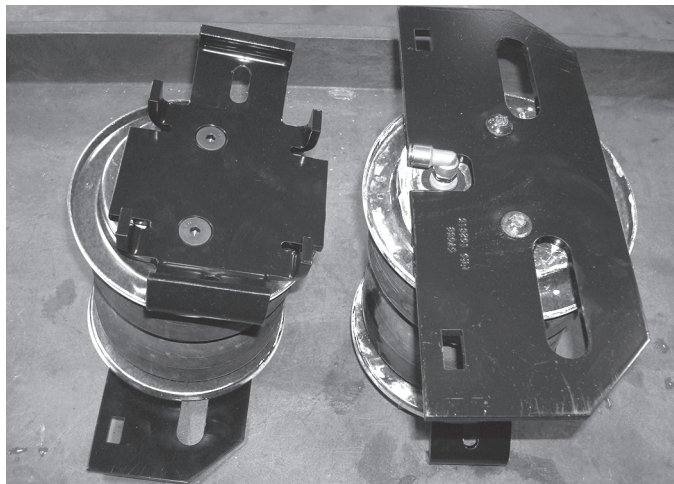
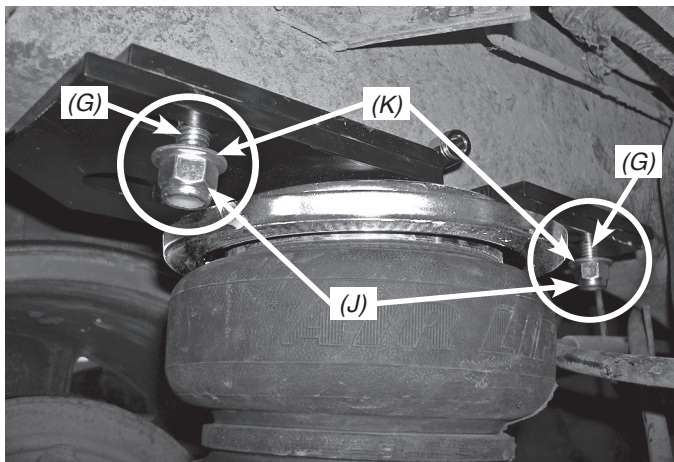

*fig. 9*

7. Figure 10 shows the finished assemblies.

*fig. 10*

### ATTACHING THE UPPER BRACKETS

1. Set the assemblies onto the axle with the fittings to the inside of the frame (Fig. 11). Align the upper air spring and frame bracket (A) (that was previously installed) slots and attach using two 3/8"-16 X 1 1/4" carriage bolts (G), two flat washers (K) and two nylon lock nuts (J). Repeat for the opposite side and leave hardware loose at this time.

*fig. 11*

## ATTACHING THE LOWER BRACKETS

1. Raise the axle or lower the frame and make sure the lower bracket has nested over the jounce bumper strike plate (Figs. 12 & 13).

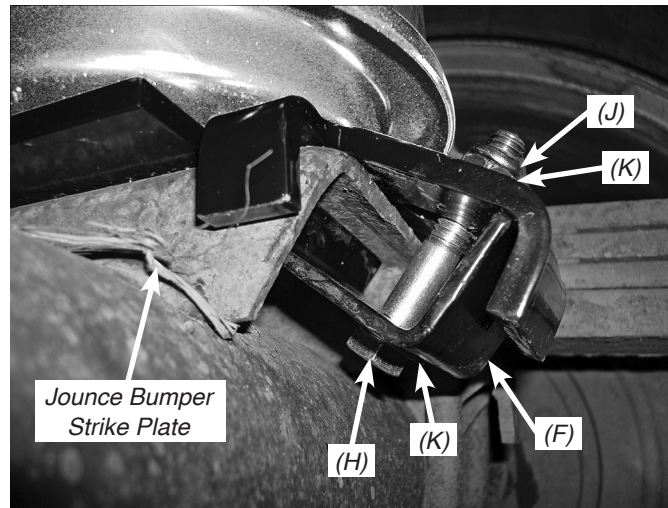

fig. 12

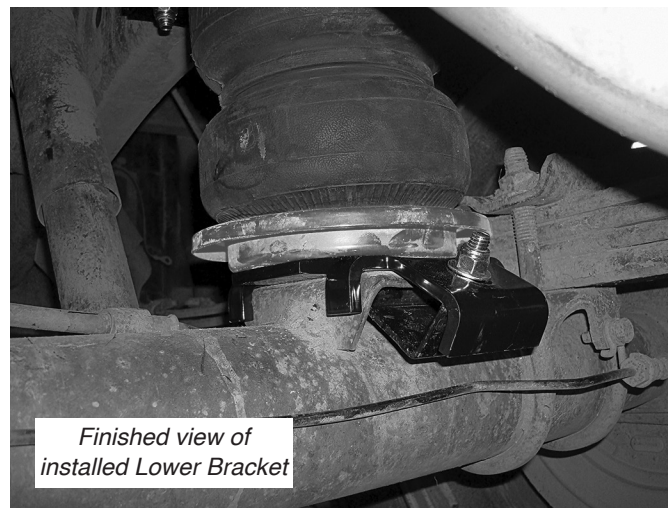

fig. 13

2. Attach the lower bracket by inserting a hex head bolt (H) through a flat washer (K) and J-clamp (F). Install the J-clamp with the short end under the jounce bumper strike plate with the bolt through the lower bracket. Cap with a flat washer (K) and nylon lock nut (J). Do this for the front and rear of the lower bracket and as the hardware is being tightened, make sure the lower bracket stays in the center of the jounce bumper strike plate. Torque the lower bracket hardware evenly to 10 lb.-ft.
3. Once the lower bracket is tight, push the top of the air spring assembly forward or backward to align the upper and lower bracket so they are parallel. Torque the upper mounting hardware to 16 lb.-ft.

## HEAT SHIELD INSTALLATION

**NOTE**

*The heat shield is installed on the exhaust pipe at the closest point to the air spring to protect the unit from the radiant heat of the exhaust system.*

1. Attach radiator clamps loosely around the exhaust pipe nearest to the spring.
2. Bend the heat shield tab out at a 90-degree angle and again half the distance up at a 90-degree angle to form an "L" shape (Fig. 14). Repeat on the other tab. Position the heat shield and insert the heat shield tabs beneath the two radiator clamps. Tighten the clamps (Fig. 15).
3. Bend the heat shield to form it around the tailpipe. Be sure to maintain a "dead air" space of 1/2" to 1" between the tailpipe and the heat shield (Fig. 16).

**NOTE**

*Make sure installation does not interfere with moving parts, gas lines, etc.*

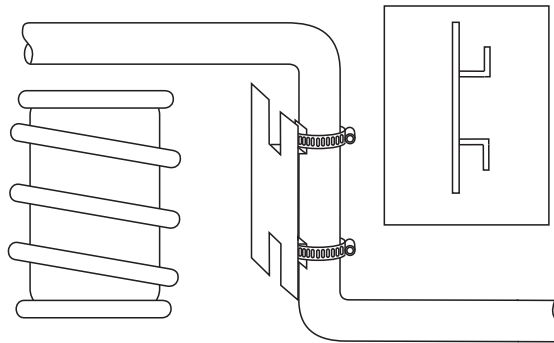
*fig. 14*

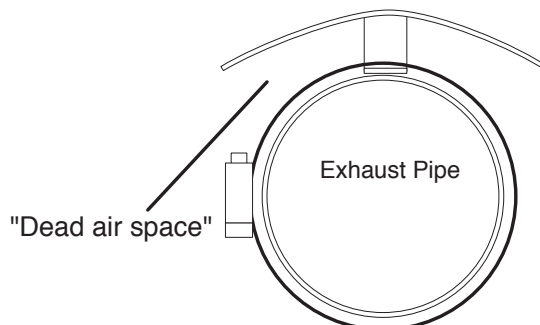
*fig. 15*

*fig. 16*

## VIEWS OF THE INSTALLED ASSEMBLY

1. Front view of the right (passenger) side assembly (Fig. 17).



fig. 17

2. Rear view of the left (driver) side assembly (Fig. 18).



fig. 18

## INSTALLING THE AIR LINES

1. Choose the locations for the Schrader valves and drill a 5/16" (8mm) hole, if necessary.

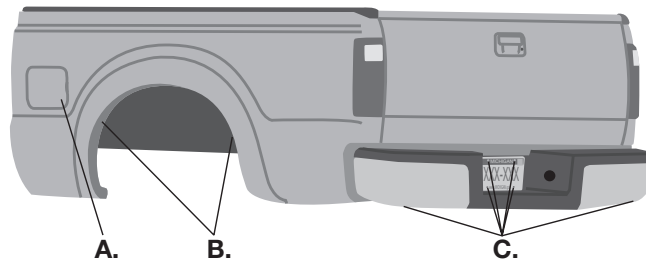

A. Inside fuel tank filler door  
B. Inside rear wheel wells

C. License plate or rear bumper area



KEEP AT LEAST 6" (152MM) OF CLEARANCE BETWEEN ALL AIR LINES AND THE EXHAUST SYSTEM. AVOID SHARP BENDS AND EDGES.

2. Make clean, square cuts with a razor blade or hose cutter when cutting the air line (AA). Do not use scissors or wire cutters.

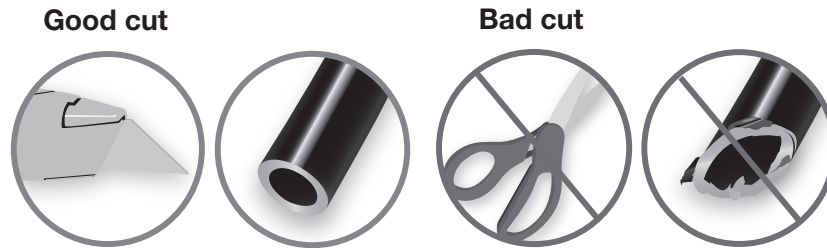

3. Use zip ties (BB) to secure the air line to fixed points along the chassis. Do not pinch or kink the air line. Leave at least 2" (51mm) of slack in the air line to allow for any movement that might pull on the air line. The minimum bend radius for the air line is 1" (25mm).
4. Install the Schrader valve in the chosen location.

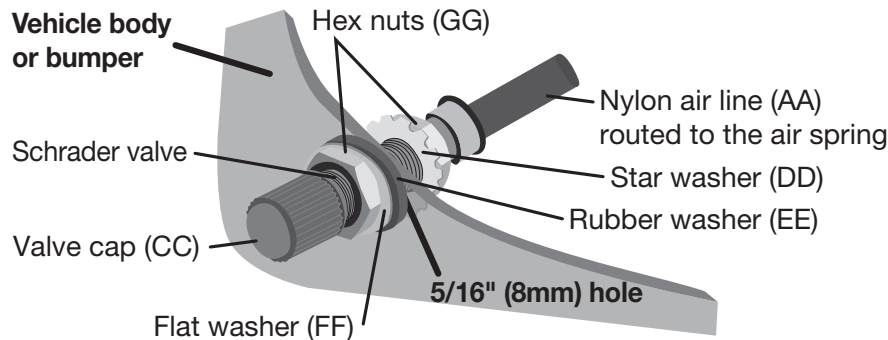

## Before Operating

### INSTALLATION CHECKLIST

- Clearance test** — Inflate the air springs to 40-60 PSI (2.8-4.1BAR) and make sure there is at least 1/2" (13mm) clearance from anything that might rub against each sleeve. Be sure to check the tire, brakes, frame, shock absorbers and brake cables.
- Leak test before road test** — Inflate the air springs to 40-60 PSI (2.8-4.1BAR) and check all connections for leaks. All leaks must be eliminated before the vehicle is road-tested.
- Heat test** — Be sure there is sufficient clearance from heat sources, at least 6" (152mm) for air springs and air lines. If a heat shield was included in the kit, install it. If there is no heat shield, but one is required, call Air Lift customer service at (800) 248-0892.
- Fastener test** — After 500 miles (800km), recheck all bolts for proper torque.
- Road test** — The vehicle should be road-tested after the initial tests. Inflate the air springs to recommended driving pressures. Drive the vehicle 10 miles (16km) and recheck for clearance, loose fasteners and air leaks.
- Operating instructions** — If professionally installed, the installer should review the operating instructions with the owner. Be sure to provide the owner with all of the paperwork that came with the kit.

## MAINTENANCE AND USE GUIDELINES

1. Check air pressure weekly.
2. Always maintain normal ride height. Never inflate beyond 100 PSI (7BAR).
3. If the system develops an air leak, use a soapy water solution to check all air line connections and the inflation valve core before deflating and removing the air spring.
4. Upon successful completion of the installation, follow these pressure requirements for the air springs.



### CAUTION

FOR SAFETY AND TO PREVENT POSSIBLE DAMAGE TO THE VEHICLE, DO NOT EXCEED MAXIMUM GROSS VEHICLE WEIGHT RATING (GVWR) OR PAYLOAD RATING, AS INDICATED BY THE VEHICLE MANUFACTURER.

ALTHOUGH THE AIR SPRINGS ARE RATED AT A MAXIMUM INFLATION PRESSURE OF 100 PSI (7BAR), THE AIR PRESSURE ACTUALLY NEEDED IS DEPENDENT ON LOAD AND GROSS VEHICLE WEIGHT RATING.

## Limited Warranty and Return Policy

Air Lift Company provides a Limited Lifetime Warranty\* to the original purchaser of its load support products, from the date of original purchase, that the products will be free from defects in workmanship and materials when used on cars and trucks as specified by Air Lift Company and under normal operating conditions, subject to the requirements and exclusions set forth in the full Limited Warranty and Return Policy.

\*Full Limited Warranty and Return Policy are available at [www.airliftcompany.com/warranty](http://www.airliftcompany.com/warranty) and are subject to change.

### WARRANTY REGISTRATION & CLAIMS

- To register your warranty, please visit <https://www.airliftcompany.com/support/warranty/register/>
- To submit a warranty claim, please visit <https://www.airliftcompany.com/support/warranty/submit-claim/>

## Need Help?

Contact our customer service department by calling (800) 248-0892, Monday through Friday. For calls from outside the USA or Canada, our local number is +1 (517) 322-2144.

**Register your warranty online at  
[www.airliftcompany.com/warranty](http://www.airliftcompany.com/warranty)**



*Thank you for purchasing Air Lift products!*



MADE IN USA  
WITH GLOBAL  
COMPONENTS

Air Lift Company • 2727 Snow Road • Lansing, MI 48917 or PO Box 80167 • Lansing, MI 48908-0167  
Toll Free (800) 248-0892 • Local (517) 322-2144 • Fax (517) 322-0240 • [www.airliftcompany.com](http://www.airliftcompany.com)

Printed in  
the USA  
JJC-0324

California: ⚠️WARNING: Cancer and Reproductive Harm - [www.P65Warnings.ca.gov](http://www.P65Warnings.ca.gov)