

LoadLifter 5000™ SERIES + Air Lift® ProSeries



Installation Guide



** LoadLifter 5000 Ultimate kit shown here*

Dodge/RAM 2500



Watch the video

Info on Table of Contents page

Kits 57289 | 88289 | 93289

For maximum effectiveness and safety, please read these instructions completely before proceeding with installation.

Failure to read these instructions can result in an incorrect installation.

Protect your Air Lift Purchase by Completing your Warranty Registration

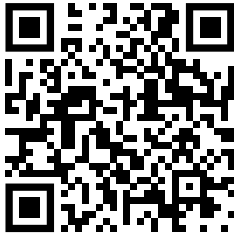

Thank you for purchasing an Air Lift load support product!

Take a photo of your sales receipt and then scan the QR code to complete your online warranty registration.

Limited Warranty and Return Policy

Air Lift Company provides a Limited Lifetime Warranty* to the original purchaser of its load support products, from the date of original purchase, that the products will be free from defects in workmanship and materials when used on cars and trucks as specified by Air Lift Company and under normal operating conditions, subject to the requirements and exclusions set forth in the full Limited Warranty and Return Policy.

*Full Limited Warranty and Return Policy are available at www.airliftcompany.com/warranty and are subject to change.

WARRANTY REGISTRATION & CLAIMS

- To register your warranty, please visit:
<https://www.airliftcompany.com/support/warranty/register/>
- To submit a warranty claim, please visit:
<https://www.airliftcompany.com/support/warranty/submit-claim/>

TABLE OF CONTENTS

2 System Overview

3 Hardware and Tools

4 Introduction

Notation Explanation
Identifying the Differences Between Kits

5 Install the System

Prepare the Vehicle
Build the Air Spring Assemblies
Finished Assemblies
Attach the Assemblies to the Frame

11 Install the Air Lines

12 Finished Installation

12 Before Operating

Installation Checklist
Maintenance and Use Guidelines

Video-enhanced installation guides

Visit airliftcompany.com/workshop/category/install-videos to access our installation video archive*.

System Overview

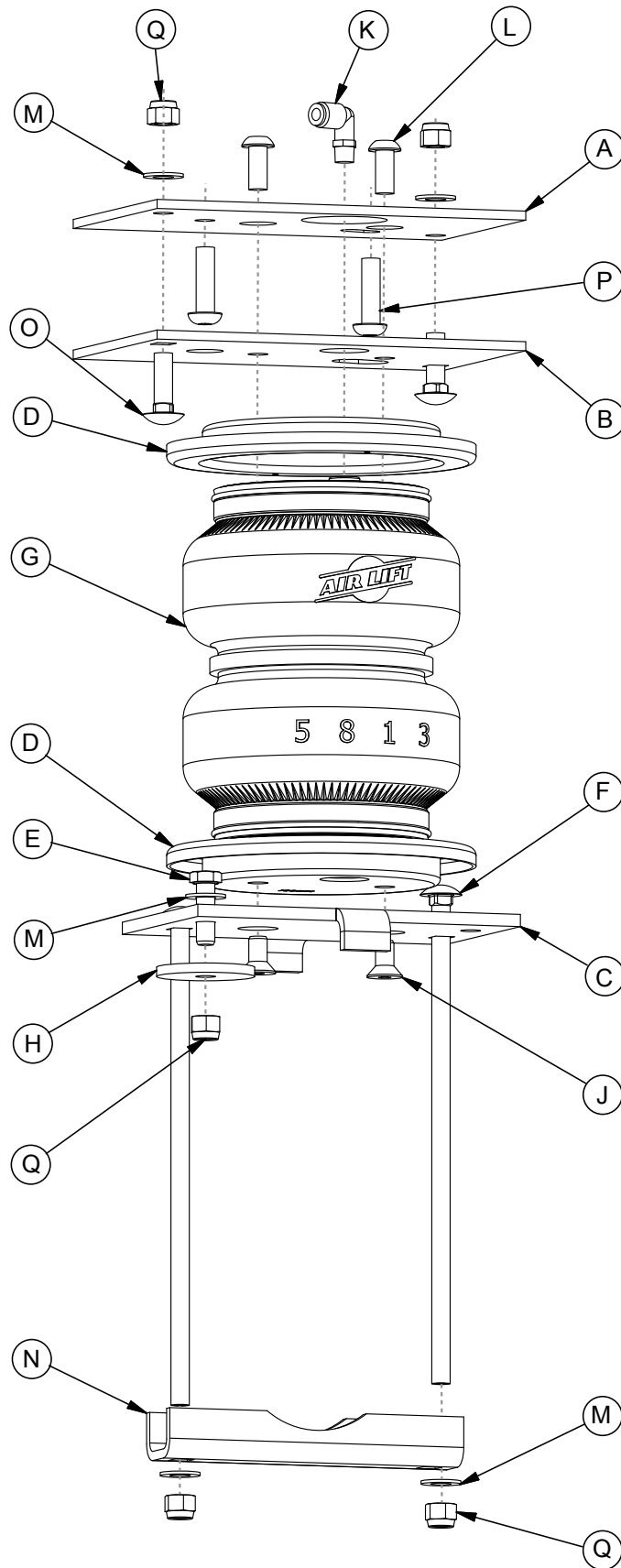

Fig. 1

Hardware and Tools

Common Parts Included in All 3 Kits

Item	Part#	Description	Qty
A	07160	Upper frame bracket.....	2
B	07161	Upper air spring bracket.....	2
C	03019	Lower bracket.....	2
E	17188	3/8"-16 x 1 1/4" Hex-head bolt.....	2
F	17387	3/8"-16 x 10" Carriage bolt.....	4
H	18260	Large flat washer.....	2
K	21837	1/8" MNPT-1/4" Swivel elbow fitting.....	2
M	18444	3/8" Flat washer.....	10
N	01531	Clamp bar	2
O	17361	3/8"-16 x 1 1/4" Carriage bolt.....	4
P	17366	M10-1.5 Button-head screw.....	4
Q	18435	3/8"-16 Nylon lock nut.....	10
AA*	20086	Air line assembly.....	1
BB*	10466	Zip ties.....	6
CC*	21230	Valve cap	2
DD*	18411	Star washer.....	2
EE*	21234	Rubber washer	2
FF*	18501	M8 Flat washer	2
GG*	21233	5/16" Hex nut	4

* These parts are not shown in the System Overview (Fig.1)

TOOLS LIST

Description.....	Qty
Standard and metric open-end or box wrenches	SET
Ratchet	1
Standard and metric, regular and deep-well sockets	SET
5/16" drill bit (very sharp)	1
9/16" Crows foot adapter	1
Heavy-duty drill	1
Torque wrench.....	1
Standard and metric hex-key wrenches	1
Hose cutter, razor blade or sharp knife	1
Hoist or floor jacks	1
Safety stands.....	2
Safety glasses.....	1
Air compressor or compressed air source	1
Spray bottle with dish soap/water solution.....	1

The photos in this manual show the LoadLifter 5000 Ultimate kit

Unique Parts in Each Kit

LoadLifter 5000™ KIT 57289

Item	Part#	Description	Qty
D	11951	Zinc-coated roll plate.....	4
G	58437	Air spring.....	2
J	17215	3/8"-24 x 3/4" Flat-head socket cap screw.....	4
L	17527	3/8"-24 x 3/4" Button-head screw.....	4

LoadLifter 5000™ ULTIMATE KIT 88289

Item	Part#	Description	Qty
D	11967	Black powder-coated roll plate.....	4
G	58496	Air spring with integrated jounce bumper.....	2
J	17215	3/8"-24 x 3/4" Flat-head socket cap screw.....	4
L	17527	3/8"-24 x 3/4" Button-head screw.....	4

Air Lift® ProSeries KIT 93289

Item	Part#	Description	Qty
D	11951	Zinc-coated roll plate.....	4
G	58937	Air spring.....	2
J	17363	3/8"-24 x 3/4" Flat-head socket cap screw (SS) ..	4
L	17376	3/8"-24 x 7/8" Button-head screw (SS).....	4
HH*	21838	Tee fitting.....	1



Missing or damaged parts? Call Air Lift customer service at (800) 248-0892 for a replacement part.

Introduction

The purpose of this publication is to assist with the installation and maintenance of the LoadLifter 5000 series and Air Lift ProSeries air spring kits. All LoadLifter 5000 series and Air Lift ProSeries kits utilize sturdy, reinforced, commercial-grade single or double, depending on the kit, convolute bellows.

The air springs are manufactured like a tire with layers of rubber and cords that control growth. LoadLifter 5000 series and Air Lift ProSeries kits provide up to 5,000 pounds (2,268kg) of load-leveling support with air adjustability from 5-100 PSI (.34-7BAR).

It is important to read and understand the entire installation guide before beginning installation or performing any maintenance, service or repair.

NOTATION EXPLANATION

Hazard notations appear in various locations in this publication. Information highlighted by one of these notations must be observed to help minimize risk of personal injury or possible improper installation, which may render the vehicle unsafe. Notes are used to help emphasize areas of procedural importance and provide helpful suggestions. The following definitions explain the use of these notations as they appear throughout this installation guide.



DANGER

INDICATES IMMEDIATE HAZARDS WHICH WILL RESULT IN SEVERE PERSONAL INJURY OR DEATH.



WARNING

INDICATES HAZARDS OR UNSAFE PRACTICES WHICH COULD RESULT IN SEVERE PERSONAL INJURY OR DEATH.



CAUTION

INDICATES HAZARDS OR UNSAFE PRACTICES WHICH COULD RESULT IN DAMAGE TO THE MACHINE OR MINOR PERSONAL INJURY.



NOTE

Used to help emphasize areas of procedural importance and provide helpful suggestions.



TECH TIP

Used to provide helpful tips to ease the installation process.

IDENTIFYING THE DIFFERENCES BETWEEN KITS

Should you need to contact Air Lift customer service, you will need to know which kit you are inquiring about: standard LoadLifter 5000, LoadLifter 5000 Ultimate or standard Air Lift ProSeries. The kits are easily identifiable by looking at the end caps on the air spring and the roll plates.

- Standard **LoadLifter 5000®** — Plastic end cap and Zinc-plated steel roll plates.
- LoadLifter 5000® Ultimate** — Plastic end cap and Black powder-coated roll plates.
- Standard **Air Lift® ProSeries** — Aluminum end cap and Zinc-plated steel roll plates.



LoadLifter 5000
Plastic end cap



LoadLifter 5000
silver zinc-plated steel roll plate



LoadLifter 5000 Ultimate
Plastic end cap



LoadLifter 5000 Ultimate
black powder-coated roll plate



Air Lift ProSeries
Aluminum end cap



Air Lift ProSeries
silver zinc-plated steel roll plate

Install the System

PREPARE THE VEHICLE

1. Raise the vehicle and support the frame with safety stands, drop the axle down to make room for the air spring assemblies to be put into position between the frame and axle (Fig. 2).

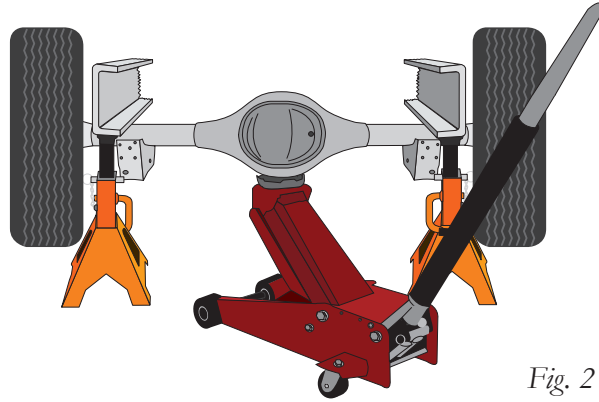

Fig. 2

2. On the left (driver's) side axle, there is a small vent tube (Fig. 3) that needs to be tied on an angle with a zip tie (BB).

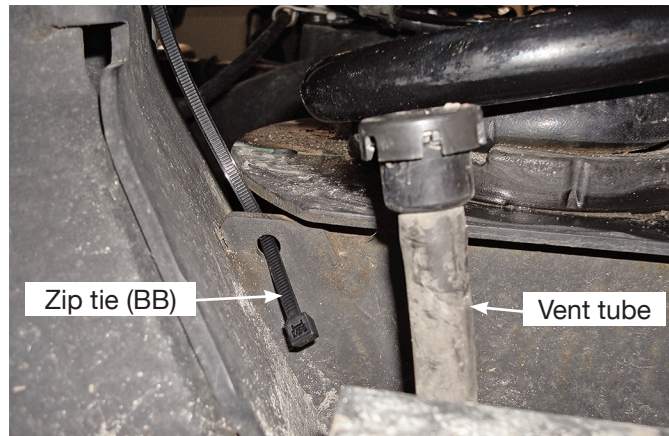

Fig. 3

3. Insert the zip tie into the small hole in the lower coil spring seat, then around the vent tube and just snug the zip tie enough to angle the tube out of the way (Fig. 4).

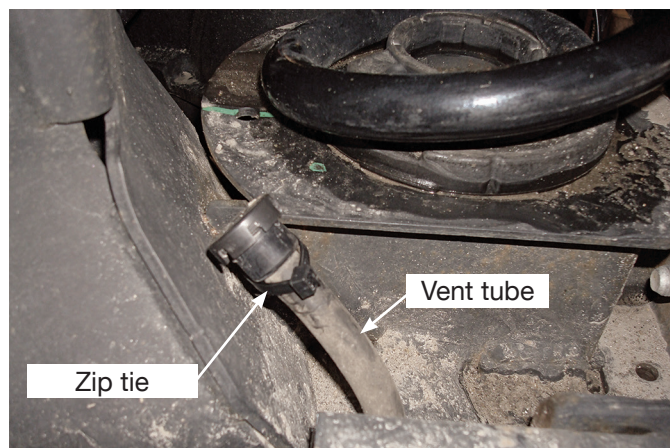

Fig. 4

- Remove the left and right side jounce bumpers (Figs. 5 & 6).

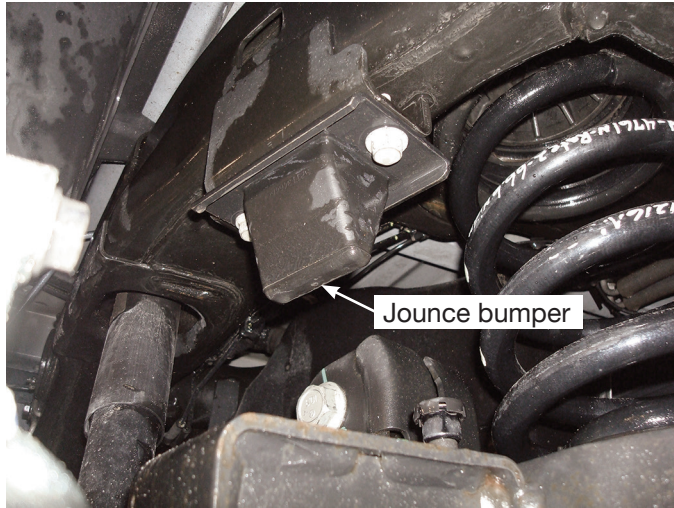

Fig. 5

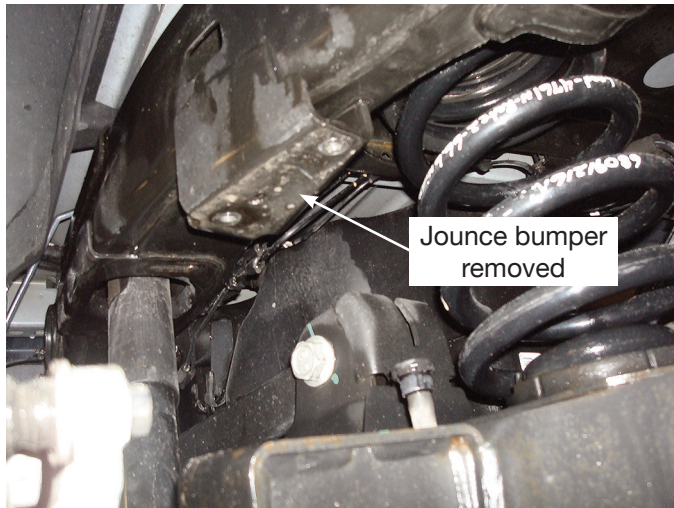

Fig. 6

- Attach the upper frame bracket (A) to the frame (Figs. 7 & 8) using the M10 button head screws (P).



The large hole in the bracket goes to the outside of the frame (toward the tire).

Driver's side

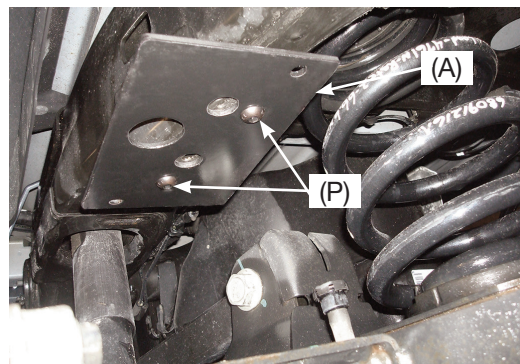

Fig. 7

Passenger's side

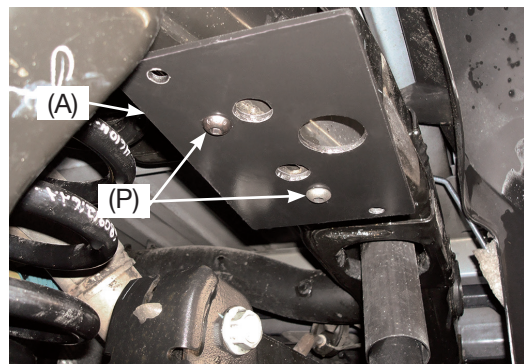

Fig. 8

- Torque the mounting hardware to 30 lb.-ft. (41Nm).

BUILD THE AIR SPRING ASSEMBLIES

1. Set a roll plate (D) over the top of each air spring (G).

NOTE

The radiused (rounded) edge of the roll plate (D) will be toward the air spring so that the air spring is seated inside both roll plates.

2. Install the swivel fitting (K) into the top of the air spring finger-tight plus one and a half turns (Fig. 9). Repeat for both air springs.

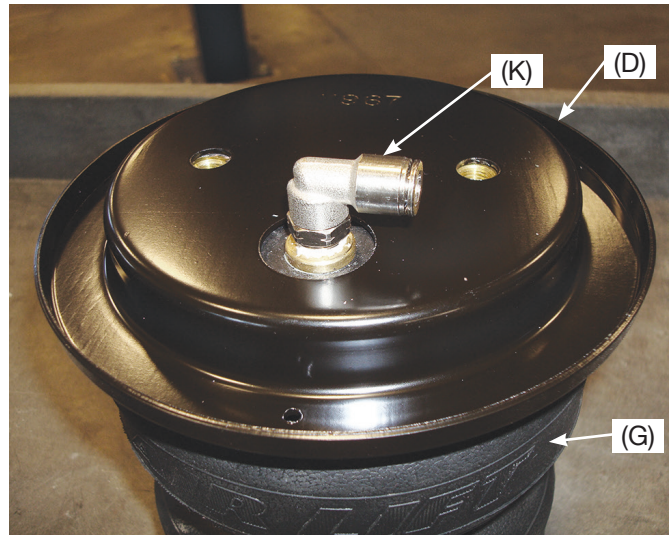

Fig. 9

3. Set both air springs in front of you with the fittings pointing at you (Fig. 10).
4. Insert the 3/8" carriage bolt (O) through the upper air spring bracket (B) in the hole at the backside only (Figs. 1 & 10).

NOTE

The upper air spring brackets will be a mirror image when set onto the air springs (see Fig. 10).

Left (driver's)
side assembly

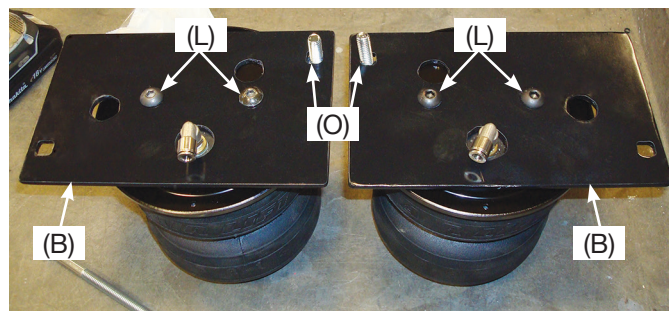

Right
(passenger's)
side
assembly

Fig. 10

5. Set both brackets onto the air springs and attach using the 3/8" button-head screws (L). Torque no more than 20 lb.-ft. (27Nm).

6. Install the large flat washer (H) onto the lower bracket (C) with 3/8" hex-head bolt (E), 3/8" flat washer (M) and 3/8" nylon lock nut (Q) as shown (Figs. 1 & 11). Tighten securely.
7. Insert the long 3/8" carriage bolts (F) into the square holes in the lower bracket (Figs. 1 & 11).

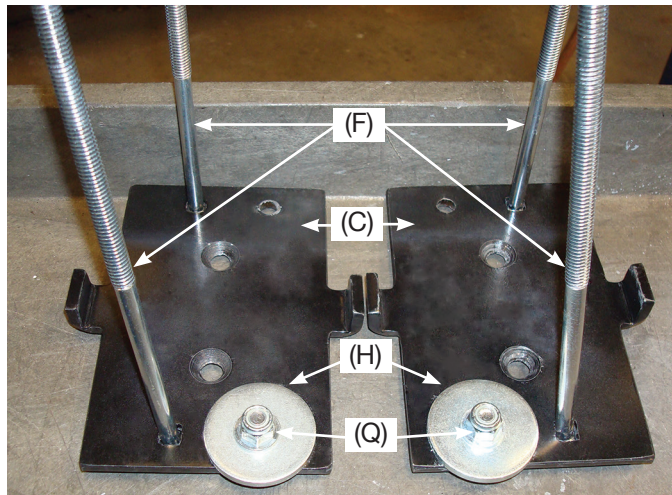

Fig. 11

8. Set a roll plate (D) over the bottom of the air spring and install the lower brackets onto the air spring assembly so that the large washer previously installed will be forward of the axle once installed (Figs. 12 & 13) using the 3/8" flat head screws (J). Torque to no more than 20 lb.-ft. (27Nm).

Left (driver's) side assembly

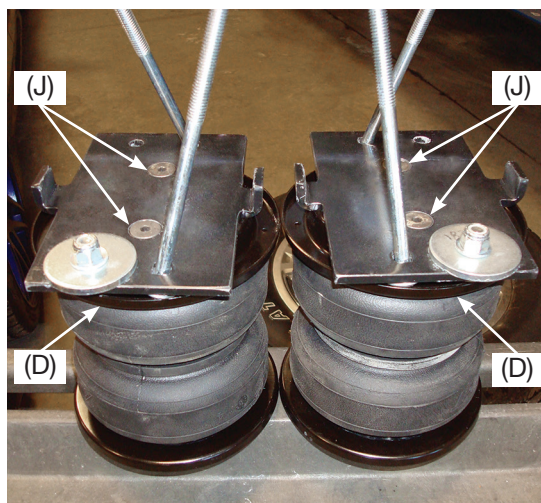

Fig. 12

Make sure the lower bracket attached with the large washer is on the same side as the open square hole in the top bracket as shown.

The large washer installed on the lower bracket will be forward of the axle once installed.

Left (driver's) side assembly



Right (passenger's) side assembly

Fig. 13

FINISHED ASSEMBLIES

Left (driver's)
side assembly



Right
(passenger's)
side assembly

Fig. 14

ATTACH THE AIR SPRING ASSEMBLIES TO THE FRAME

1. With the axle slightly hanging, set the left (driver's) side assembly on the axle, making sure that the carriage bolt (F) goes in between the brake line and the axle (Fig. 15).



Fig. 15

2. Carefully set the upper air spring bracket into position, making sure that the carriage bolt and fitting line up with the holes in the frame bracket (Fig. 16). Raise the axle up so that the brackets come together, making sure the fitting and the carriage bolt go through the holes and do not bind.

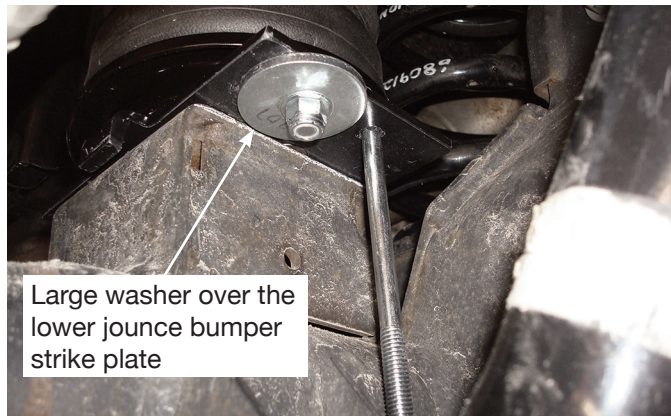

Fig. 16

3. Insert the remaining carriage bolt (O) through the open front holes from the bottom up and cap both upper carriage bolts with 3/8" flat washer (M) and 3/8" nylon lock nut (Q). Torque to 16 lb.-ft. (22Nm). Repeat for the other side.

NOTE *It may be necessary to use a 9/16" crows foot adapter to torque the nut underneath the frame.*

4. Bring the axle all the way up and position the lower bracket over the lower jounce bumper strike plate. The large washer on the bottom of the bracket should be positioned forward and over the lower jounce bumper strike plate (Fig. 17).



Right
(passenger's)
side assembly

Fig. 17

5. Set the clamp bar (N) over the two long carriage bolts (F) under the axle and cap with two 3/8" flat washers (M) and 3/8" nylon lock nuts (Q) (Fig. 18).

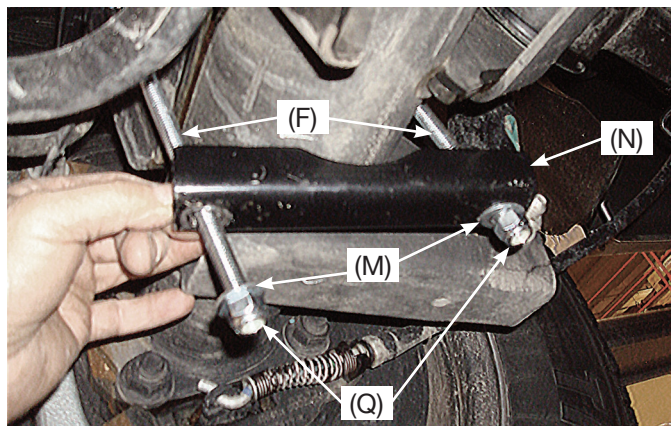

Fig. 18

6. Torque evenly to 10 lb.-ft. (14Nm) (Fig. 19). Repeat for the other side.

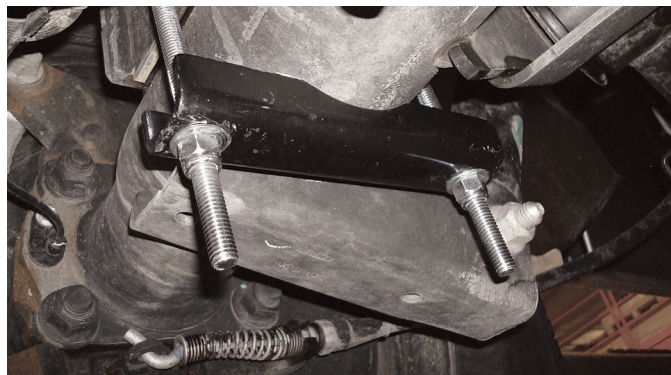
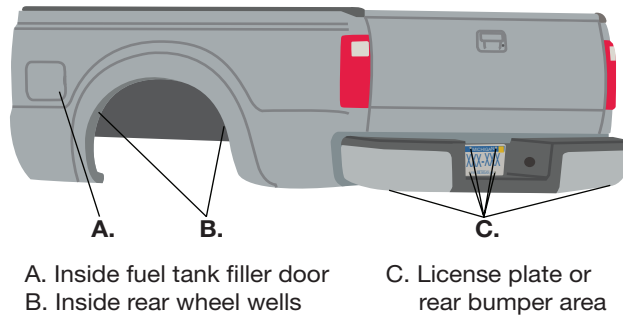

Fig. 19

7. Raise the axle or lower the vehicle and remove the safety stands.

Install the Air Lines

1. Choose the locations for the Schrader valves and drill a 5/16" (8mm) hole, if necessary.



CAUTION

KEEP AT LEAST 6" (152MM) OF CLEARANCE BETWEEN ALL AIR LINES AND THE EXHAUST SYSTEM. AVOID SHARP BENDS AND EDGES.

2. Make clean, square cuts with a razor blade or hose cutter when cutting the air line (AA). Do not use scissors or wire cutters.

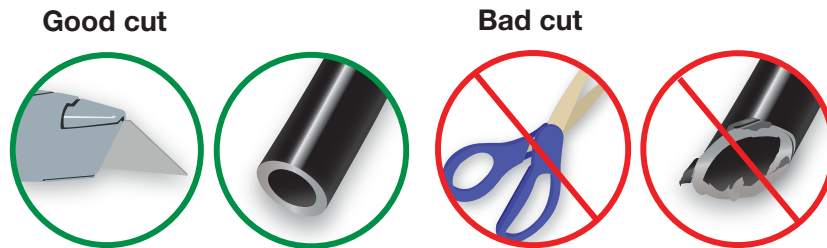

3. Use zip ties (BB) to secure the air line to fixed points along the chassis. Do not pinch or kink the air line. Leave at least 2" (51mm) of slack in the air line to allow for any movement that might pull on the air line. The minimum bend radius for the air line is 1" (25mm).
4. Install the Schrader valve in the chosen location.

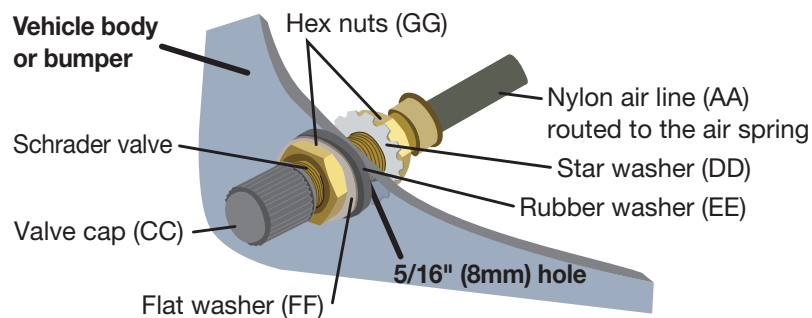

Finished Installation

The images show the finished installation of both sides.



Left (driver's) side top view

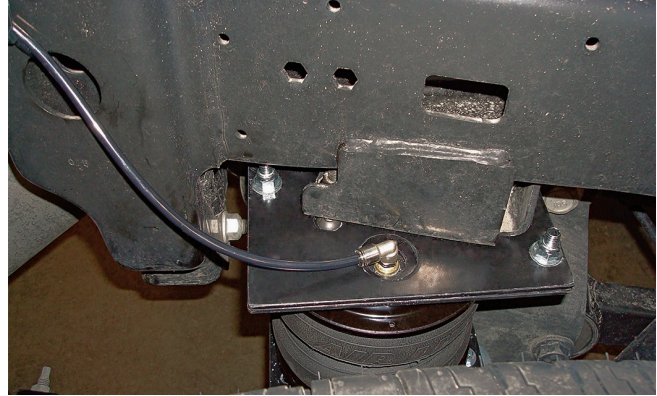

Right (passenger's) side top view

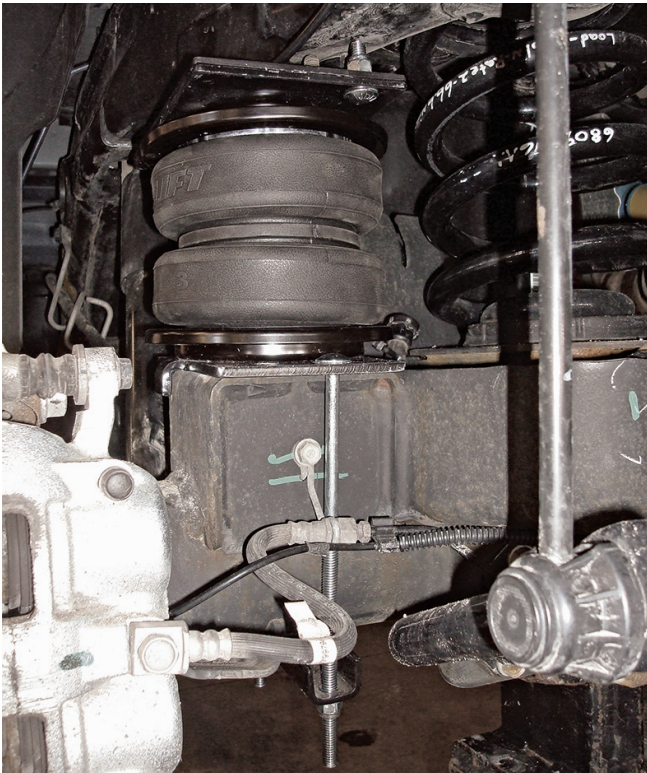

Left (driver's) side back view shown with tire removed

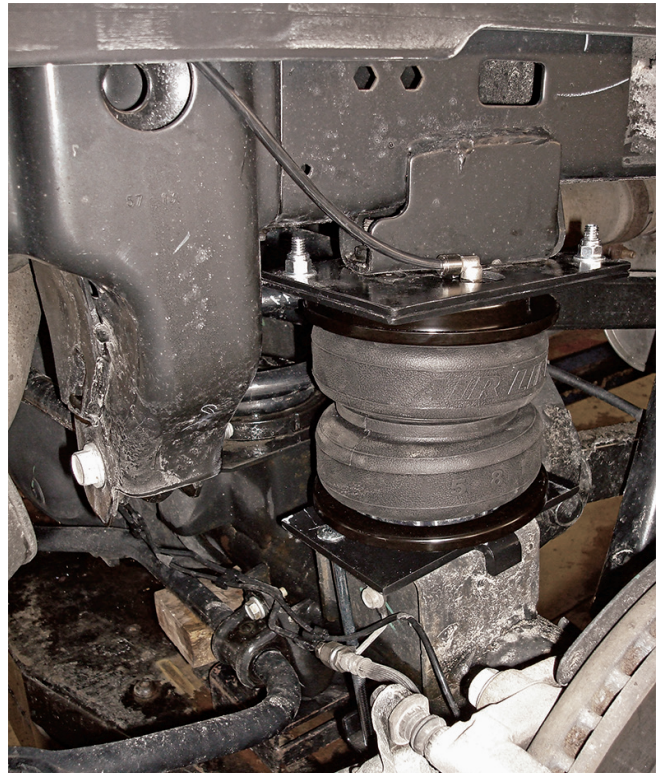

Right (passenger's) side view shown with tire removed

Congratulations!

You are now the proud owner of an Air Lift air suspension system. Enjoy!

Before Operating

INSTALLATION CHECKLIST

- ❑ **Clearance test** — Inflate the air springs to 40-60 PSI (2.8-4.1BAR) and make sure there is at least 1/2" (13mm) clearance from anything that might rub against each sleeve. Be sure to check the tire, brakes, frame, shock absorbers and brake cables.
- ❑ **Leak test before road test** — Inflate the air springs to 40-60 PSI (2.8-4.1BAR) and check all connections for leaks. All leaks must be eliminated before the vehicle is road-tested.
- ❑ **Heat test** — Be sure there is sufficient clearance from heat sources, at least 6" (152mm) for air springs and air lines. If a heat shield was included in the kit, install it. If there is no heat shield, but one is required, call Air Lift customer service at (800) 248-0892.
- ❑ **Fastener test** — After 500 miles (800km), recheck all bolts for proper torque.
- ❑ **Road test** — The vehicle should be road-tested after the initial tests. Inflate the air springs to recommended driving pressures. Drive the vehicle 10 miles (16km) and recheck for clearance, loose fasteners and air leaks.
- ❑ **Operating instructions** — If professionally installed, the installer should review the operating instructions with the owner. Be sure to provide the owner with all of the paperwork that came with the kit.

MAINTENANCE AND USE GUIDELINES

1. Check air pressure weekly.
2. Always maintain normal ride height. Never inflate beyond 100 PSI (7BAR).
3. If the system develops an air leak, use a soapy water solution to check all air line connections and the inflation valve core before deflating and removing the air spring.
4. Upon successful completion of the installation, follow these pressure requirements for the air springs.



**Minimum Recommended
Air Pressure**



Maximum Air Pressure



CAUTION

FOR SAFETY AND TO PREVENT POSSIBLE DAMAGE TO THE VEHICLE, DO NOT EXCEED MAXIMUM GROSS VEHICLE WEIGHT RATING (GVWR) OR PAYLOAD RATING, AS INDICATED BY THE VEHICLE MANUFACTURER. ALTHOUGH THE AIR SPRINGS ARE RATED AT A MAXIMUM INFLATION PRESSURE OF 100 PSI (7BAR), THE AIR PRESSURE ACTUALLY NEEDED IS DEPENDENT ON LOAD AND GROSS VEHICLE WEIGHT RATING.



Thank you for purchasing Air Lift Products!

Need Help?

Contact Air Lift Company Customer Service at (800) 248-0892
or email service@airliftcompany.com.

For calls outside the U.S. or Canada, dial +1 (517) 322-2144.



MADE IN USA
WITH GLOBAL
COMPONENTS

Air Lift Company • 2727 Snow Road • Lansing, MI 48917 or P.O. Box 80167 • Lansing, MI 48908-0167

Air Lift Company reserves the right to make changes and improvements to its products and publications at any time.
For the latest version of this manual, contact Air Lift Company at (800) 248-0892 or visit airliftcompany.com.