

Atlas

ENGINEERED BY AIR LIFT

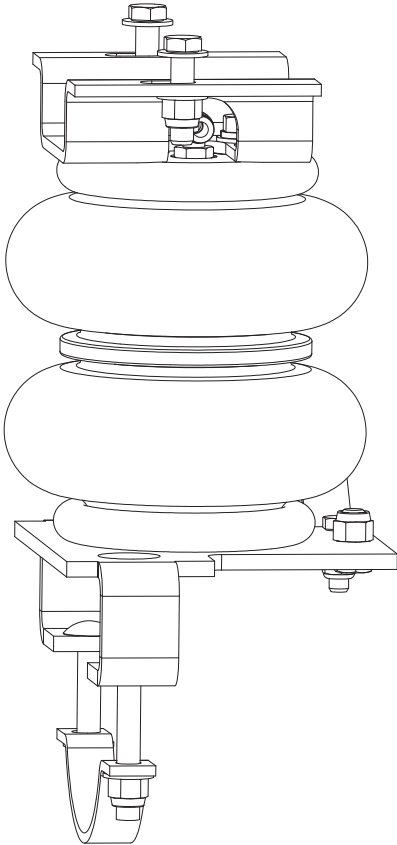

Atlas Air A5000

**Kit Number:
AA22500**

**Fits:
Chevrolet/GMC
2500/3500**

Engineered and Assembled in the USA

Installation Instructions

Before Getting Started

For optimal performance and safety, read all instructions thoroughly before beginning the installation. Failure to read and follow these instructions may lead to improper installation and potential safety risks.

Tools Needed

- Standard and metric open-end or box wrenches
- Adjustable wrench
- Ratchet
- Metric, 9/16", and 1/2" deep-well sockets
- 7/32" Hex-key wrench (socket if available)
- 3/8" and 5/16" drill bits (very sharp)
- Heavy-duty drill
- Torque wrench
- Standard and metric hex-key wrenches
- Hose cutter, razor blade, or sharp knife
- Hoist or floor jacks
- Safety stands
- Safety glasses
- Air compressor or compressed air source
- Spray bottle w/ dish soap/water solution

AA22500 Exploded Installation View

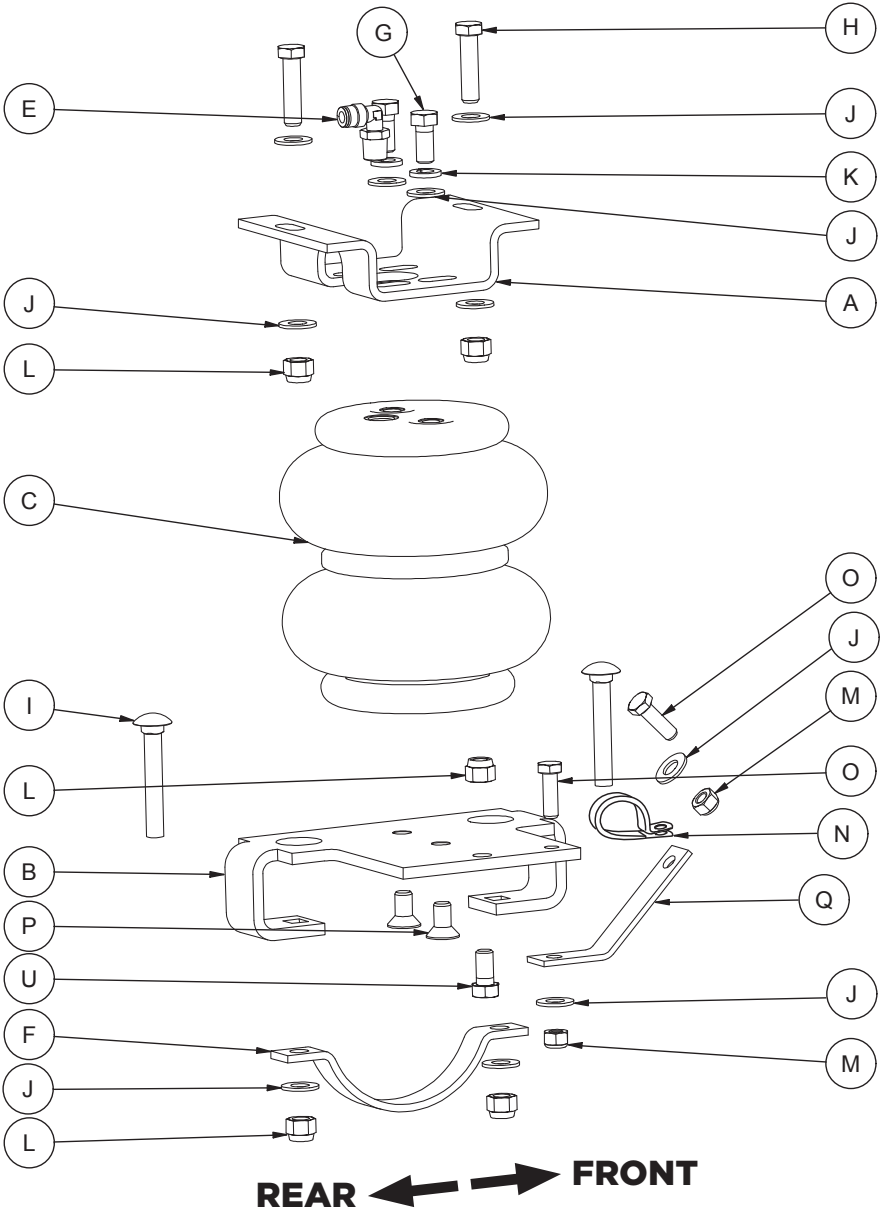

Parts List

Part	Part No.	Part Description	QTY
A	07197	Upper bracket	2
B	03083	Lower bracket	2
C	58403	Air spring	2
E		90-degree Swivel push to connect fitting	2
F	10451	Axle strap	2
G		3/8-16 X 3/4" Hex head cap screw	4
H		3/8-16 X 1 1/2" Hex cap screw	4
I		3/8-16 X 2 1/2" Carriage bolts	4
J		3/8" Flat washer	18
K		3/8" Lock washer	4
L		3/8"-16 Nylon lock nut	10
M		5/16-18 Nylon lock nut	2
N		Brake line clip	1
O		5/16-18 X 1" Hex head cap screw	2
P		3/8-16 X 3/4" Flat head screw	4
Q	10421	Brake line bracket	1
U		3/8-16 X 3/4" Hex head cap screw	2
AA*		Air line assembly	1
BB*		Zip ties	6
CC*		Valve cap	2
DD*		Star washer	2
EE*		Rubber washer	2
FF*		M8 Flat washer	2
GG*		5/16" Hex nut	4

* These parts are not shown in the Exploded Installation View section

Introduction

This guide is here to walk you through setting up and taking care of your Atlas Air™ A5000 air suspension kit. They are built tough—commercial-grade and reinforced for durability. Think of the air springs like tires: layers of rubber and strong cords work together to manage pressure and maintain shape to help control your ride.

With Atlas Air A5000, you'll get up to 5000 pounds (2268 kg) of support to keep your ride level, and you can fine-tune the pressure anywhere between 5 and 100 PSI (0.34 to 7 BAR). Before diving into the installation or doing any kind of upkeep, make sure to read through the entire manual—it'll save you time and headaches down the road.

Symbols



THIS MEANS THERE'S AN IMMEDIATE AND SERIOUS RISK. IF IGNORED, IT WILL LEAD TO SEVERE INJURY OR EVEN DEATH. ALWAYS TAKE THESE WARNINGS SERIOUSLY.



SIGNALS A DANGEROUS SITUATION OR UNSAFE ACTION THAT COULD CAUSE SEVERE INJURY OR DEATH. IT'S NOT A GUARANTEE, BUT IT'S A BIG RISK—PROCEED CAREFULLY.



These callouts highlight useful advice or important reminders to keep you on track during the process. Don't skip them—they often save time.



Little tricks of the trade to help installation go more smoothly. These tips can make a big difference if you're aiming for a clean, efficient job.

Information

This kit does not increase the Gross Vehicle Weight Rating (GVWR) or payload capacity of your vehicle. Always refer to your vehicle's Safety Compliance Certification Label or owner's manual, and do not exceed the manufacturer's maximum load rating.

- **Gross Vehicle Weight Rating (GVWR):**

The maximum allowable weight of a fully loaded vehicle, including passengers, cargo, and fluids. This value—along with other important specifications like tire size, rim size, and inflation pressure—is located on the vehicle's Safety Compliance Certification Label.

- **Payload:**

The maximum combined weight of passengers and cargo your vehicle is designed to carry. Payload is calculated by subtracting the vehicle's base curb weight from its GVWR.

Air Pressure Guidelines

While Atlas Air A5000 air springs are engineered to handle a **maximum inflation pressure of 100 PSI (7.0 BAR)**, the actual pressure required will vary based on the vehicle's load and total weight. Always adjust air pressure according to your specific load conditions—**not solely based on the maximum pressure limit.**

Ride Height and Suspension Limits

Always maintain the correct ride height by adjusting the air pressure based on your current load. Shock absorbers typically act as the suspension limiters on extension. If they do not, particularly on off-road vehicles, consider using limiting straps to prevent overextension.

Brake System Considerations

Vehicles equipped with a **rear brake proportioning valve** may experience changes in braking performance when using a load-assist product. **Consult your dealer** before installation. If your vehicle **does not** have a proportioning valve or is equipped with an **anti-lock brake system (ABS)**, the installation of an air spring kit **will not affect braking performance.**

System Install

Build Air Springs

1. *Install 90-Degree Elbow Fitting*

Thread the 90-degree elbow fitting (E) into the top port of the air spring (C). Tighten by hand until finger-tight, then rotate an additional 1 1/2 turns. Only tighten on the metal hex portion—do not overtighten.

2. *Attach Upper Bracket*

Position the air springs in front of you with the air fittings facing you. Place the upper bracket (A) on top of each air spring. Secure the driver side assembly with two 3/8" bolts (G), lock washers (K), and flat washers (J), using the two slotted holes closest to you on the upper bracket. Do the same for the passenger side, using the two slotted holes furthest away from you, opposite the driver side. Leave the bolts slightly loose for adjustment later.

3. *Install Bolt in Lower Bracket – Driver Side Only*

Position the lower bracket (B) so the flanges are facing down and insert a 5/16" bolt (O) into the small hole in the corner of the lower bracket.

4. *Install Bolt and Nut – 2500 HD Models Only*

For 2500 HD models, install a 3/8" bolt (U) and lock nut (L) through the larger hole centered on the edge of the lower bracket (B), with the bolt head facing downward. Tighten securely.

5. *Insert Carriage Bolts into Lower Bracket*

Insert two 3/8" carriage bolts (I) into the large holes, feeding them into the square holes in the legs of the lower bracket (B).

6. *Attach Lower Bracket to Air Spring*

Secure the lower bracket (B) to the bottom of the air spring assembly using two 3/8" flat-head screws (P). Tighten securely.

Vehicle Preinstall Steps

1. *Raise and Support the Vehicle*

Lift the vehicle and securely support the axle using safety stands. Position the stands as wide apart as possible along the axle for maximum stability.

2. *Create Clearance for Installation*

Lower the axle or raise the vehicle frame to provide enough space for the air spring assemblies to be positioned between the frame and the axle.

3. *Remove Jounce Bumpers*

Remove and discard both jounce bumpers located under the frame rails.

Air Spring Installation into Vehicle

For the 3500 Model, skip to step 6.

2500 HD Models

1. Position the Assembly

Place the assembly with the 3/8" bolt (U) previously installed onto the driver's (left) side.

2. Index Lower Bracket Legs

Index the lower bracket legs under the jounce bumper strike plate.

3. Hook Under Strike Plate

With the lower bracket parallel to the strike plate, hook one leg under the side of the strike plate. Rotate the assembly until the other leg hooks under the opposite side.

4. Verify Hook Engagement

Ensure both lower bracket legs are fully hooked under the strike plate.

5. Continue to Step 7.



On the driver's (left) side, there may be a small bracket with a nut that is not attached to anything. Trim this bracket off the axle to allow clearance for the air spring assembly.

3500 Models

6. Position the Assembly

Place the assembly onto the strike plate with the lower bracket legs positioned forward and behind the axle.

7. Orient the Elbow Fitting

Ensure the elbow fitting points toward the rear of the vehicle on the driver's (left) side, and toward the front on the passenger's (right) side.

8. Install Upper Bracket Hardware

Insert two 3/8" bolts (H) and flat washers (J) through the jounce bumper holes in the frame and slotted holes in the upper bracket. Raising the axle slightly at this point can help the upper bracket touch the frame.

9. Secure the Bracket

Install two flat washers (J) and two nylon lock nuts (L) onto the bolts to secure the upper bracket.

10. Tighten and Align

Push the bracket inboard toward the center of the frame and tighten both upper bolts.

11. Raise the Axle and Remove Stands

Raise the axle completely and remove the safety stands previously used to support the frame.

12. Align the Assemblies

Upper Adjustment: Move the assembly forward or backward using the slotted holes.

Lower Adjustment: Shift the lower bracket in or out on the axle to achieve vertical alignment of the air spring.

13. Torque Upper Bracket Bolts

Tighten the upper mounting bolts to 20 lb.-ft. (27Nm).

14. Install and Torque Axle Strap

Attach the axle strap (F) across the lower bracket using two 3/8" flat washers (J) and two nylon lock nuts (L) on the carriage bolts. Torque evenly to 16 lb.-ft. (22Nm).

15. Attach the Emergency Brake Line Bracket

Attach the emergency brake line bracket (Q) to the lower bracket using the previously installed 5/16" bolt (O), a flat washer (J), and a nylon lock nut (M).

16. Attach the Clip to the Brake Line

Snap the brake line clip (N) onto the emergency brake line.

17. Secure the Clip to the Bracket

Secure the clip to the bracket using a 5/16" bolt (O), two flat washers (J), and a nylon lock nut (M).

18. Final Brake Line Adjustment

Adjust the brake line bracket and clip assembly to ensure there is no binding or tension on the emergency brake cable. Tighten all hardware securely.



Ensure the emergency brake cable does not rub against the air spring when fully inflated. If necessary, adjust the bracket and clip assembly for proper clearance.

Air Lines Installation

1. *Select Schrader Valve Locations*

Choose suitable locations for the Schrader valves. If necessary, drill a 5/16" (8 mm) hole at each selected location. Common locations for mounting are inside fuel tank filler door, inside rear wheel wells, or by the license plate mount or rear bumper area.

2. *Measure and Cut the Air Line*

Measure the length of air line needed to reach your intended Schrader valve locations. Cut the air line (AA) using a sharp razor blade or hose cutter to make clean, square cuts. Do not use scissors or wire cutters, as these can deform the tubing and compromise the seal.

3. *Route and Secure the Air Line*

Route the air line (AA) from each air spring to the chosen Schrader valve locations. Plan the route to avoid sharp edges, moving parts, and heat sources. Once routed, use zip ties (BB) to secure the air line to stable points along the vehicle chassis. Do not pinch or kink the line. Leave at least 2" (51 mm) of slack to accommodate movement. The air line's minimum bend radius is 1" (25 mm).



Maintain a minimum of 5 1/2" (140 mm) clearance between all air lines and any part of the exhaust system. Avoid routing air lines over sharp edges or making tight bends.

4. *Install Schrader Valves*

Install the Schrader valves into the selected locations.

Heat Shield Installation (if provided in kit)

1. *Position the Heat Shield*

Place the heat shield over the exhaust pipe near the air spring. Maintain at least 1/2" (13 mm) of clearance between the shield and the exhaust surface. Depending on the design of the heat shield included in your kit, you may need to bend the tabs or the shield itself to achieve proper fitment and spacing.

2. *Install the Air Line Thermal Sleeve (if included)*

If your kit includes a thermal sleeve, slide it over the section of air line that runs closest to the exhaust. This sleeve helps protect the line from excessive heat exposure.

3. *Secure Components with Hose Clamps*

Use hose clamps to secure the heat shield and thermal sleeve (if used). Apply double clamps where needed for added security. Make final adjustments to ensure all components are properly spaced and firmly in place.

Checklist

Ensure the air suspension system is correctly installed and safe for operation by completing the following checks:

1. Clearance Verification

Inflate the air springs to 50 PSI (3.45 BAR). Confirm a minimum clearance of 1/2" (13 mm) between the air springs and any adjacent components, including tires, brake assemblies, the vehicle frame, shock absorbers, and brake lines. Adjust as needed to prevent contact during operation.

2. Heat Clearance Check

Verify that all air springs and air lines are positioned at least 5 1/2" (140 mm) away from any heat sources.

3. Leak Inspection

With the system pressurized to 50 PSI (3.45 BAR) inspect all fittings, air lines, and connections for leaks. All leaks must be fully resolved prior to road testing.

4. Road Test Procedure

Inflate the air springs to the recommended operating pressure and conduct a 10-mile (16 km) road test. Upon completion, re-inspect for adequate clearance, air leaks, and secure fasteners.

5. Torque Confirmation

After 500 miles (800 km) of driving, recheck and torque all hardware to the specified values to ensure long-term stability and safety.

Adjusting Air Pressure

Stability

Properly adjusting air pressure is key to achieving both vehicle stability and correct ride height. Begin by increasing pressure until the suspension feels firm and controlled—without exceeding the maximum of 100 PSI (7 BAR). Ensure the vehicle sits level across all four corners. Uneven loads may require redistributing cargo or adjusting air pressure side to side.

Comfort

Ride quality is also influenced by air pressure. Too much or too little can cause harshness or instability. As a general rule:

- If the vehicle frequently bottoms out on the frame, increase air pressure.
- If the ride feels overly stiff or harsh, reduce air pressure slightly.

Adjust gradually to find the best balance between comfort and control.

Guidelines

1. Check System Pressure Weekly

Inspect the air pressure in the system at least once a week to ensure consistent performance and ride quality.

2. Maintain Proper Ride Height

Always operate the vehicle at the recommended ride height. Do not exceed 100 PSI (7.0 BAR) under any circumstances.

3. Inspect for Air Leaks as Needed

If you suspect a leak, follow these steps to identify and address the issue:

- a. Inflate the air springs to 50 PSI (3.45 BAR).
- b. Spray all air line connections and the inflation valve with a mild solution of liquid dish soap and water.
- c. Wait 30 seconds and observe for any bubbles, which indicate a leak.
- d. Recheck the system pressure after 24 hours. A pressure loss of 2–4 PSI (0.14–0.28 BAR) is normal after initial installation. If the pressure drops by more than 5 PSI (0.34 BAR), recheck for leaks.
- e. Once testing is complete, adjust the air spring to the minimum pressure required for proper ride height.

4. Inspect Hardware and Component Alignment

Periodically check that all fasteners are properly torqued. Also, check for signs of rubbing or misalignment, and realign components as needed.

5. Clean the Air Springs

Occasionally, spray the air springs with clean water to remove mud, dirt, or debris that may collect during use.

6. Lift the Vehicle with Care

If lifting the vehicle by the frame, reduce system pressure to 5 PSI (0.34 BAR) to relieve tension on the air springs and mounting hardware.

Repair Guide

Fixing Leaks on Barbed Fittings

1. Cut the air line 1 1/2" (38 mm) behind the existing fitting.
2. Use pliers or locking pliers to twist and pull the air line off the fitting.

REMEMBER...



Do not cut lengthwise, as this may damage the barbs and lead to future leaks.

3. Reinstall the air line and clamp (if applicable), making sure the air line fully covers all barbs for a proper seal.

Fixing Leaks on Push-to-Connect (PTC) Fittings

To Disconnect:

1. Release all air pressure from the system.
2. Push the air line inward toward the fitting.
3. While holding the air line in, press the collar inward toward the fitting.
4. With the collar depressed, pull the air line out.

Before Reconnecting:

5. Cut off the end of the air line just beyond the witness mark to ensure a clean, undamaged sealing surface.
6. If the fitting leaks at the threads, remove it, apply fresh thread sealant, and reinstall it 1 1/2 turns beyond finger-tight.

To Reconnect:

7. Push the air line into the fitting until fully seated.
8. Gently pull back on the air line to verify a secure connection.

Warranty

What this warranty covers

Atlas Products Company provides a warranty to the original purchaser of its Load Support Products, for the periods of time listed at AtlasProducts.com, by product line, from the date of original purchase, that the products will be free from defects in workmanship and materials when used on cars and trucks as specified by Atlas Products Company and under normal operating conditions, subject to the requirements and exclusions set forth below.

What this warranty does not cover

The warranty does not apply to products that have been improperly applied, improperly installed, or that have not been maintained in accordance with the installation instructions furnished with all products. This warranty does not apply and is void if damage or failure is caused by: accident, abuse, misuse (including but not limited to racing or off-road activities or commercial use), abnormal use, faulty installation, liquid contact, fire, earthquake or other external cause; operating the product outside Atlas Products Company's instructions, specifications or guidelines; or service, alteration, maintenance or repairs performed by anyone other than Atlas Products Company to the product from its purchased condition. This warranty also does not apply to: consumable parts, such as batteries, cosmetic damage, including but not limited to scratches or dents; defects caused by normal wear and tear or otherwise due to the normal aging of the product, or if any serial or identification number has been removed or defaced from the product. Atlas Products Company reserves the right to change the design of any product without assuming any obligation to modify any product previously manufactured.

Limitation of liability

To the extent permitted by law, this warranty and the remedies set forth herein are exclusive and in lieu of all other warranties, remedies and conditions, whether oral, written, statutory, express or implied. ATLUS PRODUCTS COMPANY DISCLAIMS ALL STATUTORY AND IMPLIED WARRANTIES, INCLUDING WITHOUT LIMITATION, WARRANTIES OF MERCHANTABILITY AND FITNESS FOR A PARTICULAR PURPOSE AND WARRANTIES AGAINST HIDDEN OR LATENT DEFECTS TO THE EXTENT PERMITTED BY LAW. To the extent such warranties cannot be disclaimed, such implied warranties shall apply only for the warranty period specified above. Please note that some states do not allow limitation on how long an implied warranty (or condition) lasts. So the above limitation may not apply to you.

Except as provided in this warranty and to the extent permitted by law, Atlus Products Company shall not be liable for any direct, special, incidental or consequential damages resulting from any breach of warranty or condition, or arising in connection with the sale, use or repair of Atlus products, or under any other legal theory, including but not limited to loss of use, loss of revenue, loss of actual or anticipated profits, loss of the use of money, loss of business, loss of opportunity, loss of goodwill, and loss of reputation. Atlus Products Company's maximum liability shall not in any case exceed the purchase price paid by you for the Atlus product. Please note that some states do not allow the exclusion or limitation of incidental or consequential damages, so the above limitation or exclusion may not apply to you.

How to get service

If a defect in workmanship or materials causes your Atlas product to become inoperable within the warranty period, before returning any defective product, email Atlas Products Company at support@atlusproducts.com. The consumer shall be responsible for removing the defective product from the vehicle (including any labor charges) and returning it, shipping costs prepaid, to Atlas Products Company for verification. You must prove to the satisfaction of Atlas Products Company the date of original purchase of your Atlas product. A minimum \$10 shipping and handling charge (plus applicable sales tax) will apply to all warranty claims. You must also pack the product to minimize the risk of it being damaged in transit. If we receive a product in damaged condition as the result of shipping, we will notify you and you must seek a claim with the shipper.

What Atlas Products Company will do

If you submit a valid claim to Atlas Products Company during the warranty period, and Atlas determines that the product was defective, Atlas Products Company will, at its option, repair your Atlas product or furnish you with a new or rebuilt product. Atlas Products Company will not reimburse you for repairs or replacement parts provided by other parties. Your repaired or replacement Atlas product will be returned to you (subject to payment of the required warranty claim shipping and handling charge), and it will be covered under the warranty for the balance of the warranty period, if any. When a product or part is replaced, any replacement item becomes your property and the replaced item becomes the property of Atlas Products Company. You are responsible for the installation/reinstallation (including any labor charges) of the product.

How the law relates to this warranty

This warranty gives you specific legal rights and you may also have other rights which vary from state to state. By this warranty, Atlas Products Company does not limit or exclude your rights except as allowed by law. To fully understand your rights, you should consult the laws of your state.

Customer Support

For Customer Service support, please contact us at:
support@atlusproducts.com

Atlas Products Company reserves the right to make changes and improvements to its products and publications at any time.



Engineered and Assembled in the USA

Document No. AM-1221
Revision (022510)
ECR 10488

California:  WARNING: Cancer and Reproductive Harm - www.P65Warnings.ca.gov