

Atlas Air A5000

**Kit Number:
AA26260**

**Fits:
Ford Super Duty
F-250/F-350 4WD
SRW (Single Rear Wheel)**

Engineered and Assembled in the USA

Installation Instructions

Before Getting Started

For optimal performance and safety, read all instructions thoroughly before beginning the installation. Failure to read and follow these instructions may lead to improper installation and potential safety risks.

Tools Needed

- Standard and metric open-end or box wrenches
- Ratchet
- 9/16" Ratchet combo wrench
- Standard and metric sockets
- 9/16" Crow's foot adapter
- Torque wrench
- 5/16" Drill bit (very sharp)
- Heavy-duty drill
- Standard and metric hex-key wrenches
- Flat-tip screwdriver
- Hose cutter, razor blade, or sharp knife
- Hoist or floor jacks
- Safety stands
- Safety glasses
- Air compressor or compressed air source
- Spray bottle w/ dish soap/water solution

AA26260 Exploded Installation View

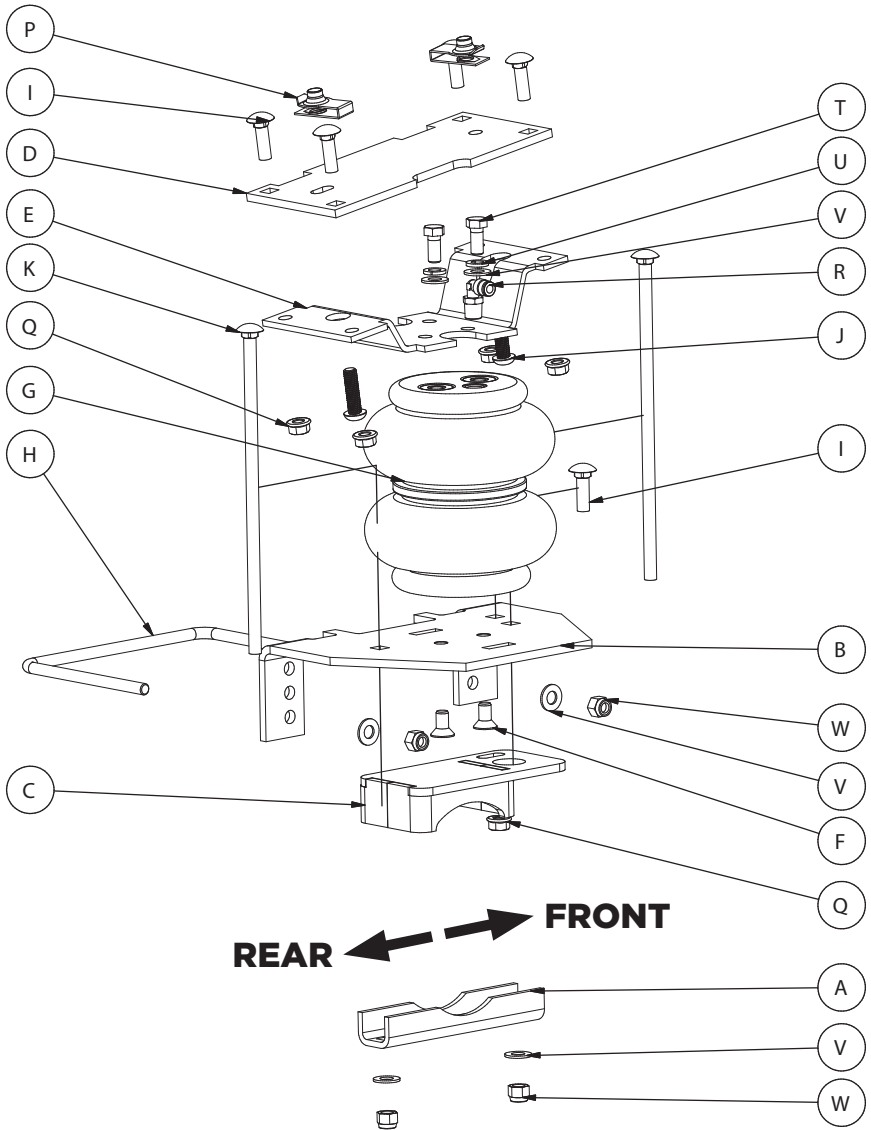

Parts List

Part	Part No.	Part Description	QTY
A	01531	Clamp bar	2
B	03073	Lower bracket, main plate	2
C	03224	Lower bracket, cup	2
D	07091	Upper bracket, frame	2
E	11438	Bracket, air spring	2
F		3/8-16 X 7/8" Flat head socket cap screw	4
G	58403	Air spring	2
H		U-bolt	2
I		3/8-16 X 1" Carriage bolts	10
J		M10-1.50 X 35 Button head cap screw	4
K		3/8-16 X 10" Carriage bolts	4
P		M10-1.5 Universal nuts	4
Q		3/8-16 Serrated flange lock nuts	10
R		90-degree Swivel push to connect fitting	2
T		3/8-16 X 3/4" Hex cap screw	4
U		3/8" Split lock washer	4
V		3/8" Flat washer	12
W		3/8-16 Nylon lock nut	8
AA*		Air line assembly	1
BB*		Zip ties	6
CC*		Valve cap	2
DD*		Star washer	2
EE*		Rubber washer	2
FF*		M8 Flat washer	2
GG*		5/16" Hex nut	4

* These parts are not shown in the Exploded Installation View section

Introduction

This guide is here to walk you through setting up and taking care of your Atlas Air™ A5000 air suspension kit. They are built tough—commercial-grade and reinforced for durability. Think of the air springs like tires: layers of rubber and strong cords work together to manage pressure and maintain shape to help control your ride.

With Atlas Air A5000, you'll get up to 5000 pounds (2268 kg) of support to keep your ride level, and you can fine-tune the pressure anywhere between 5 and 100 PSI (0.34 to 7 BAR). Before diving into the installation or doing any kind of upkeep, make sure to read through the entire manual—it'll save you time and headaches down the road.

Symbols



THIS MEANS THERE'S AN IMMEDIATE AND SERIOUS RISK. IF IGNORED, IT WILL LEAD TO SEVERE INJURY OR EVEN DEATH. ALWAYS TAKE THESE WARNINGS SERIOUSLY.



SIGNALS A DANGEROUS SITUATION OR UNSAFE ACTION THAT COULD CAUSE SEVERE INJURY OR DEATH. IT'S NOT A GUARANTEE, BUT IT'S A BIG RISK—PROCEED CAREFULLY.



These callouts highlight useful advice or important reminders to keep you on track during the process. Don't skip them—they often save time.



Little tricks of the trade to help installation go more smoothly. These tips can make a big difference if you're aiming for a clean, efficient job.

Information

This kit does not increase the Gross Vehicle Weight Rating (GVWR) or payload capacity of your vehicle. Always refer to your vehicle's Safety Compliance Certification Label or owner's manual, and do not exceed the manufacturer's maximum load rating.

- **Gross Vehicle Weight Rating (GVWR):**

The maximum allowable weight of a fully loaded vehicle, including passengers, cargo, and fluids. This value—along with other important specifications like tire size, rim size, and inflation pressure—is located on the vehicle's Safety Compliance Certification Label.

- **Payload:**

The maximum combined weight of passengers and cargo your vehicle is designed to carry. Payload is calculated by subtracting the vehicle's base curb weight from its GVWR.

Air Pressure Guidelines

While Atlas Air A5000 air springs are engineered to handle a **maximum inflation pressure of 100 PSI (7.0 BAR)**, the actual pressure required will vary based on the vehicle's load and total weight. Always adjust air pressure according to your specific load conditions—**not solely based on the maximum pressure limit.**

Ride Height and Suspension Limits

Always maintain the correct ride height by adjusting the air pressure based on your current load. Shock absorbers typically act as the suspension limiters on extension. If they do not, particularly on off-road vehicles, consider using limiting straps to prevent overextension.

Brake System Considerations

Vehicles equipped with a **rear brake proportioning valve** may experience changes in braking performance when using a load-assist product. **Consult your dealer** before installation. If your vehicle **does not** have a proportioning valve or is equipped with an **anti-lock brake system (ABS)**, the installation of an air spring kit **will not affect braking performance.**

System Install

Build Air Springs

1. Install Swivel Fitting

Install the 90-degree swivel fitting (R) into the port on top of the air spring (G). Tighten finger-tight, then turn an additional 1 1/2 rotations.

2. Attach Upper Bracket

Set the upper air spring bracket (E) onto the top of the air spring with the bent flange ends facing upwards. Using one set of mounting holes, secure it with 3/8"-16 X 3/4" hex cap screws (T), 3/8" lock washers (U), and 3/8" flat washers (V). Install the second bracket on the other air spring using the opposite holes to create left- and right-hand assemblies. Torque all hardware to no more than 20 lb.-ft. (27Nm).

3. Insert Carriage Bolts into Lower Bracket

With the lower bracket flanges facing downward, insert two 3/8"-16 x 10" carriage bolts (K) through the square holes in the lower bracket main plate (B).

4. Attach Lower Bracket to Air Spring

Place the lower bracket main plate assemblies onto the air springs with the flanges and threaded portions of the carriage bolts facing up, away from the air spring. Attach using 3/8"-16 X 3/4" flat-head socket cap screws (F). Torque to no more than 20 lb.-ft. (27Nm).



The flange on the lower bracket must be installed on the opposite side of the swivel fitting located at the top of the air spring.

5. Install Lower Bracket Cup

Insert a 3/8"-16 x 1" carriage bolt (I) through the top of the open square hole of the lower bracket. Flip the assembly over and place the lower bracket cup (C) onto the lower bracket main plate over the carriage bolts. Secure it with a serrated flange lock nut (Q). Snug the bolt, but leave it loose enough to allow the bracket to move freely in the slot.

6. Verify Assembly Orientation

Ensure both driver's (left) side and passenger's (right) side assemblies are oriented correctly with the flange on the opposite side of the air fitting.

Vehicle Preinstall Steps

1. Raise and Support the Vehicle

Raise the vehicle and securely support it using safety stands or an equivalent method. Ensure the axle can be safely lowered away from the frame to allow room for installing the air spring assemblies between the axle and the frame.

2. Remove Jounce Bumper Assemblies

Unbolt and remove the jounce bumper assemblies from beneath the frame on both the driver and passenger sides.

3. Remove Clip-In Studs

Using a screwdriver, pry on the hinged end of each clip-in stud and pull all four (two per side) out from the frame.

4. Install Universal Nuts

Install the universal nuts (P) into the frame rail, ensuring the threaded holes align with the frame holes to allow bolt installation. A flat-tip screwdriver works well to position the universal nuts properly.

5. Install Upper Frame Brackets

Insert the 3/8"-16 x 1" carriage bolts (I) through the top of the upper frame brackets (D). Mount each bracket onto the frame using M10-1.5 x 35mm button-head cap screws (J). Ensure the centered slot cutout and larger round holes in the bracket face inward, away from the tire, and the elongated hole points toward the front of the vehicle. Torque all hardware to 38 lb.-ft. (52Nm).

Air Spring Installation into Vehicle

1. Position the Air Spring Assemblies

With the vehicle supported by safety stands, lower the axle or raise the body to create clearance. Set the driver's (left) and passenger's (right) air spring assemblies into position. For single rear wheel (SRW) vehicles, rest the lower bracket cup on the jounce bumper strike plate; for dual rear wheel (DRW) vehicles, rest it directly on the axle. If a sway bar is present, insert the carriage bolts through the clamp bar (A) while placing the assemblies.

2. Seat the Lower Bracket Against the Leaf Spring

Push the lower bracket flush against the leaf spring stack. The flanges on the lower bracket should lock onto the sides of the U-bolt. On the driver's side, position the long carriage bolt between the hard brake line and axle. On the passenger's side, position the carriage bolt behind the brake line.

3. Install U-Bolts Around the Stock U-Bolt Assembly

Wrap the U-bolts (H) around the stock U-bolt and leaf spring assembly and insert them through the topmost holes in the lower bracket main plates. Cap each with a 3/8" flat washer (V) and a 3/8" nylon lock nut (W). Snug the bolts evenly, just enough to hold the lower bracket flush against the stock U-bolts—do not torque yet.

4. Align and Secure Upper Frame Bracket Carriage Bolts

Ensure the 90-degree swivel fittings are pointing inward toward the vehicle center. While raising the axle or lowering the body, align the upper frame bracket carriage bolts with the air spring bracket holes. Cap each carriage bolt with a 3/8" serrated flange lock nut (Q). Snug the bolts, then torque to 31 lb.-ft. (42Nm). Finish raising the axle or lowering the body and remove the safety stands.

5. Install and Torque Lower Clamp Bar Hardware

If not already done, place the lower clamp bars (A) over the carriage bolts under the axle. Attach using 3/8" flat washers (V) and 3/8" nylon lock nuts (W). Evenly torque the lower clamp bar hardware to 16 lb.-ft. (22Nm). Then, torque the previously installed U-bolt hardware to 10 lb.-ft. (14Nm). For sway bar applications, it is acceptable to tighten the front carriage bolt hardware more than the rear to gain clearance on the sway bar. A 9/16" crowfoot adapter may be necessary to properly torque the hardware.

6. Trim Front Carriage Bolt if Needed

On vehicles with a sway bar, cut the front carriage bolt just below the nut to prevent contact with the sway bar.

7. Torque Upper Frame Bracket Nuts

Torque the nut (Q) securing the upper frame bracket to 32 lb.-ft. (43Nm) on both sides.

8. Inspect and Adjust Brake and ABS Lines

Ensure the brake and ABS lines are not rubbing against the lower bracket carriage bolt. If needed, carefully push or pull the hard brake line away and tie off the ABS line to gain clearance. On the passenger side, it may be necessary to remove the ABS tree mount from the top of the bracket and reattach it to the back of the bracket.



Brake or ABS lines must not rub against the carriage bolt. Always reposition lines or secure them with zip ties as needed to ensure proper clearance.

Air Lines Installation

1. *Select Schrader Valve Locations*

Choose suitable locations for the Schrader valves. If necessary, drill a 5/16" (8 mm) hole at each selected location. Common locations for mounting are inside fuel tank filler door, inside rear wheel wells, or by the license plate mount or rear bumper area.

2. *Measure and Cut the Air Line*

Measure the length of air line needed to reach your intended Schrader valve locations. Cut the air line (AA) using a sharp razor blade or hose cutter to make clean, square cuts. Do not use scissors or wire cutters, as these can deform the tubing and compromise the seal.

3. *Route and Secure the Air Line*

Route the air line (AA) from each air spring to the chosen Schrader valve locations. Plan the route to avoid sharp edges, moving parts, and heat sources. Once routed, use zip ties (BB) to secure the air line to stable points along the vehicle chassis. Do not pinch or kink the line. Leave at least 2" (51 mm) of slack to accommodate movement. The air line's minimum bend radius is 1" (25 mm).



Maintain a minimum of 5 1/2" (140 mm) clearance between all air lines and any part of the exhaust system. Avoid routing air lines over sharp edges or making tight bends.

4. *Install Schrader Valves*

Install the Schrader valves into the selected locations.

Heat Shield Installation (if provided in kit)

1. *Position the Heat Shield*

Place the heat shield over the exhaust pipe near the air spring. Maintain at least 1/2" (13 mm) of clearance between the shield and the exhaust surface. Depending on the design of the heat shield included in your kit, you may need to bend the tabs or the shield itself to achieve proper fitment and spacing.

2. *Install the Air Line Thermal Sleeve (if included)*

If your kit includes a thermal sleeve, slide it over the section of air line that runs closest to the exhaust. This sleeve helps protect the line from excessive heat exposure.

3. *Secure Components with Hose Clamps*

Use hose clamps to secure the heat shield and thermal sleeve (if used). Apply double clamps where needed for added security. Make final adjustments to ensure all components are properly spaced and firmly in place.

Checklist

Ensure the air suspension system is correctly installed and safe for operation by completing the following checks:

1. Clearance Verification

Inflate the air springs to 50 PSI (3.45 BAR). Confirm a minimum clearance of 1/2" (13 mm) between the air springs and any adjacent components, including tires, brake assemblies, the vehicle frame, shock absorbers, and brake lines. Adjust as needed to prevent contact during operation.

2. Heat Clearance Check

Verify that all air springs and air lines are positioned at least 5 1/2" (140 mm) away from any heat sources.

3. Leak Inspection

With the system pressurized to 50 PSI (3.45 BAR) inspect all fittings, air lines, and connections for leaks. All leaks must be fully resolved prior to road testing.

4. Road Test Procedure

Inflate the air springs to the recommended operating pressure and conduct a 10-mile (16 km) road test. Upon completion, re-inspect for adequate clearance, air leaks, and secure fasteners.

5. Torque Confirmation

After 500 miles (800 km) of driving, recheck and torque all hardware to the specified values to ensure long-term stability and safety.

Adjusting Air Pressure

Stability

Properly adjusting air pressure is key to achieving both vehicle stability and correct ride height. Begin by increasing pressure until the suspension feels firm and controlled—without exceeding the maximum of 100 PSI (7 BAR). Ensure the vehicle sits level across all four corners. Uneven loads may require redistributing cargo or adjusting air pressure side to side.

Comfort

Ride quality is also influenced by air pressure. Too much or too little can cause harshness or instability. As a general rule:

- If the vehicle frequently bottoms out on the frame, increase air pressure.
- If the ride feels overly stiff or harsh, reduce air pressure slightly.

Adjust gradually to find the best balance between comfort and control.

Guidelines

1. Check System Pressure Weekly

Inspect the air pressure in the system at least once a week to ensure consistent performance and ride quality.

2. Maintain Proper Ride Height

Always operate the vehicle at the recommended ride height. Do not exceed 100 PSI (7.0 BAR) under any circumstances.

3. Inspect for Air Leaks as Needed

If you suspect a leak, follow these steps to identify and address the issue:

- a. Inflate the air springs to 50 PSI (3.45 BAR).
- b. Spray all air line connections and the inflation valve with a mild solution of liquid dish soap and water.
- c. Wait 30 seconds and observe for any bubbles, which indicate a leak.
- d. Recheck the system pressure after 24 hours. A pressure loss of 2–4 PSI (0.14–0.28 BAR) is normal after initial installation. If the pressure drops by more than 5 PSI (0.34 BAR), recheck for leaks.
- e. Once testing is complete, adjust the air spring to the minimum pressure required for proper ride height.

4. Inspect Hardware and Component Alignment

Periodically check that all fasteners are properly torqued. Also, check for signs of rubbing or misalignment, and realign components as needed.

5. Clean the Air Springs

Occasionally, spray the air springs with clean water to remove mud, dirt, or debris that may collect during use.

6. Lift the Vehicle with Care

If lifting the vehicle by the frame, reduce system pressure to 5 PSI (0.34 BAR) to relieve tension on the air springs and mounting hardware.

Repair Guide

Fixing Leaks on Barbed Fittings

1. Cut the air line 1 1/2" (38 mm) behind the existing fitting.
2. Use pliers or locking pliers to twist and pull the air line off the fitting.

REMEMBER...



Do not cut lengthwise, as this may damage the barbs and lead to future leaks.

3. Reinstall the air line and clamp (if applicable), making sure the air line fully covers all barbs for a proper seal.

Fixing Leaks on Push-to-Connect (PTC) Fittings

To Disconnect:

1. Release all air pressure from the system.
2. Push the air line inward toward the fitting.
3. While holding the air line in, press the collar inward toward the fitting.
4. With the collar depressed, pull the air line out.

Before Reconnecting:

5. Cut off the end of the air line just beyond the witness mark to ensure a clean, undamaged sealing surface.
6. If the fitting leaks at the threads, remove it, apply fresh thread sealant, and reinstall it 1 1/2 turns beyond finger-tight.

To Reconnect:

7. Push the air line into the fitting until fully seated.
8. Gently pull back on the air line to verify a secure connection.

Warranty

What this warranty covers

Atlas Products Company provides a warranty to the original purchaser of its Load Support Products, for the periods of time listed at AtlasProducts.com, by product line, from the date of original purchase, that the products will be free from defects in workmanship and materials when used on cars and trucks as specified by Atlas Products Company and under normal operating conditions, subject to the requirements and exclusions set forth below.

What this warranty does not cover

The warranty does not apply to products that have been improperly applied, improperly installed, or that have not been maintained in accordance with the installation instructions furnished with all products. This warranty does not apply and is void if damage or failure is caused by: accident, abuse, misuse (including but not limited to racing or off-road activities or commercial use), abnormal use, faulty installation, liquid contact, fire, earthquake or other external cause; operating the product outside Atlas Products Company's instructions, specifications or guidelines; or service, alteration, maintenance or repairs performed by anyone other than Atlas Products Company to the product from its purchased condition. This warranty also does not apply to: consumable parts, such as batteries, cosmetic damage, including but not limited to scratches or dents; defects caused by normal wear and tear or otherwise due to the normal aging of the product, or if any serial or identification number has been removed or defaced from the product. Atlas Products Company reserves the right to change the design of any product without assuming any obligation to modify any product previously manufactured.

Limitation of liability

To the extent permitted by law, this warranty and the remedies set forth herein are exclusive and in lieu of all other warranties, remedies and conditions, whether oral, written, statutory, express or implied. ATLUS PRODUCTS COMPANY DISCLAIMS ALL STATUTORY AND IMPLIED WARRANTIES, INCLUDING WITHOUT LIMITATION, WARRANTIES OF MERCHANTABILITY AND FITNESS FOR A PARTICULAR PURPOSE AND WARRANTIES AGAINST HIDDEN OR LATENT DEFECTS TO THE EXTENT PERMITTED BY LAW. To the extent such warranties cannot be disclaimed, such implied warranties shall apply only for the warranty period specified above. Please note that some states do not allow limitation on how long an implied warranty (or condition) lasts. So the above limitation may not apply to you.

Except as provided in this warranty and to the extent permitted by law, Atlus Products Company shall not be liable for any direct, special, incidental or consequential damages resulting from any breach of warranty or condition, or arising in connection with the sale, use or repair of Atlus products, or under any other legal theory, including but not limited to loss of use, loss of revenue, loss of actual or anticipated profits, loss of the use of money, loss of business, loss of opportunity, loss of goodwill, and loss of reputation. Atlus Products Company's maximum liability shall not in any case exceed the purchase price paid by you for the Atlus product. Please note that some states do not allow the exclusion or limitation of incidental or consequential damages, so the above limitation or exclusion may not apply to you.

How to get service

If a defect in workmanship or materials causes your Atlas product to become inoperable within the warranty period, before returning any defective product, email Atlas Products Company at support@atlusproducts.com. The consumer shall be responsible for removing the defective product from the vehicle (including any labor charges) and returning it, shipping costs prepaid, to Atlas Products Company for verification. You must prove to the satisfaction of Atlas Products Company the date of original purchase of your Atlas product. A minimum \$10 shipping and handling charge (plus applicable sales tax) will apply to all warranty claims. You must also pack the product to minimize the risk of it being damaged in transit. If we receive a product in damaged condition as the result of shipping, we will notify you and you must seek a claim with the shipper.

What Atlas Products Company will do

If you submit a valid claim to Atlas Products Company during the warranty period, and Atlas determines that the product was defective, Atlas Products Company will, at its option, repair your Atlas product or furnish you with a new or rebuilt product. Atlas Products Company will not reimburse you for repairs or replacement parts provided by other parties. Your repaired or replacement Atlas product will be returned to you (subject to payment of the required warranty claim shipping and handling charge), and it will be covered under the warranty for the balance of the warranty period, if any. When a product or part is replaced, any replacement item becomes your property and the replaced item becomes the property of Atlas Products Company. You are responsible for the installation/reinstallation (including any labor charges) of the product.

How the law relates to this warranty

This warranty gives you specific legal rights and you may also have other rights which vary from state to state. By this warranty, Atlas Products Company does not limit or exclude your rights except as allowed by law. To fully understand your rights, you should consult the laws of your state.

Customer Support

For Customer Service support, please contact us at:
support@atlusproducts.com

Atlas Products Company reserves the right to make changes and improvements to its products and publications at any time.



Engineered and Assembled in the USA

Document No. AM-1223
Revision (022510)
ECR 10488

California:  WARNING: Cancer and Reproductive Harm - www.P65Warnings.ca.gov